

WIPER AND WASHER SYSTEMS

TABLE OF CONTENTS

	page		page
GENERAL INFORMATION			
INTRODUCTION	1	WASHER NOZZLE AND PLUMBING.....	5
WINDSHIELD WIPER SYSTEM	1	DIAGNOSIS AND TESTING	
WINDSHIELD WASHER SYSTEM.....	1	WIPER SYSTEM.....	5
REAR WIPER AND WASHER SYSTEM	2	WASHER SYSTEM	7
DESCRIPTION AND OPERATION		WIPER SWITCH AND WASHER SWITCH.....	8
WIPER ARM AND BLADE.....	2	INTERMITTENT WIPE RELAY.....	9
WIPER LINKAGE AND PIVOT.....	2	REMOVAL AND INSTALLATION	
WIPER MOTOR.....	3	WIPER BLADE	10
WIPER SWITCH AND WASHER SWITCH.....	3	WIPER ARM.....	11
CENTRAL TIMER MODULE	4	WIPER LINKAGE AND PIVOT.....	12
INTERMITTENT WIPE RELAY.....	4	WIPER MOTOR.....	13
WASHER RESERVOIR	4	INTERMITTENT WIPE RELAY.....	15
WASHER PUMP	5	WIPER SWITCH AND WASHER SWITCH.....	15
WASHER FLUID LEVEL SENSOR.....	5	WASHER SYSTEM	17

GENERAL INFORMATION

INTRODUCTION

Windshield and rear liftgate glass wiper and washer systems are standard factory-installed equipment on this model. Refer to 8W-53 - Wipers in Group 8W - Wiring Diagrams for complete circuit descriptions and diagrams.

WINDSHIELD WIPER SYSTEM

An intermittent windshield wiper system is standard equipment on this model. The intermittent wiper system lets the driver select from either of two wiper speeds, low or high, or the intermittent wipe delay mode. A knob on the end of the multi-function switch stalk is rotated to select the desired wiper speed, or the intermittent wipe delay mode and interval.

On models equipped with a base version of the Central Timer Module (CTM), the intermittent wipe mode delay times are driver adjustable from about one-half second to about eighteen seconds. On models equipped with a high-line version of the CTM, the intermittent wipe mode delay times are speed sensitive. Above about sixteen kilometers-per-hour (ten miles-per-hour) the delay is driver adjustable from about one-half second to about eighteen seconds. Below about sixteen kilometers-per-hour (ten miles-per-hour) the high-line CTM doubles the delay time, or provides delays of about one second to about thir-

ty-six seconds. The intermittent wipe mode is provided by delay logic and relay control circuitry contained within the CTM, and an intermittent wipe relay.

The windshield wipers will operate only when the ignition switch is in the Accessory or On positions. A fuse located in the junction block protects the circuitry of the windshield wiper system.

Following are general descriptions of the major components in the windshield wiper system. Refer to the owner's manual in the vehicle glove box for more information on the features, use and operation of the windshield wiper system.

WINDSHIELD WASHER SYSTEM

An electrically operated windshield washer system is standard equipment. A knob on the end of the multi-function switch stalk is depressed toward the steering column to activate the washer system. A washer reservoir in the engine compartment holds the washer fluid, which is pressurized by a pump when the windshield washer switch is actuated. The windshield washer pump feeds the pressurized washer fluid through the washer system plumbing to the windshield washer nozzles.

A standard equipment low washer fluid warning lamp in the instrument cluster will warn the driver when the washer fluid level needs to be checked. Refer to Group 8E - Instrument Panel Systems for more information on this feature.

GENERAL INFORMATION (Continued)

The washers will operate only when the ignition switch is in the Accessory or On positions. A fuse located in the junction block protects the circuitry of the washer system.

Following are general descriptions of the major components in the windshield washer system. Refer to the owner's manual in the vehicle glove box for more information on the features, use and operation of the windshield washer system.

REAR WIPER AND WASHER SYSTEM

A rear wiper and washer system is standard factory-installed equipment on this model. The rear wiper is a single speed intermittent-cycle wiper system. A single rear window switch module in the instrument panel lower bezel contains two separate switches. One switch controls both the rear wiper and washer systems, while the second switch controls the rear window defogger system.

The rear wiper motor has an integral electronic timer module, and is mounted inside the liftgate below the rear window glass. The rear washer system has a dedicated washer pump and plumbing, but shares the windshield washer reservoir located in the engine compartment.

The rear wiper and washer systems will operate only when the ignition switch is in the On position. A fuse in the junction block protects the circuitry of both the rear wiper and washer systems.

Refer to the owner's manual in the vehicle glove box for more information on the features, use and operation of the rear wiper and washer system.

DESCRIPTION AND OPERATION

WIPER ARM AND BLADE

All Durango models have two 50-centimeter (19.69-inch) windshield wiper blades with non-replaceable rubber elements (squeegees). The driver side and passenger side wiper blades are not interchangeable. The driver side blade features an additional bridge, which provides an additional set of claws to retain the wiper squeegees than the six sets of claws used on the passenger side blade. These wiper blades include an anti-lift feature. The wiper blades and squeegees must be oriented correctly when installed on the wiper arms for the anti-lift feature to be effective. See Wiper Blade in the Removal and Installation section of this group for more information. The standard rear wiper uses a single 40.0-centimeter (15.75-inch) wiper blade with a non-replaceable rubber element (squeegee).

Caution should be exercised to protect the rubber squeegees from any petroleum-based cleaners or contaminants, which will rapidly deteriorate the rubber.

If the squeegees are damaged, worn, or contaminated, the entire wiper blade assembly must be replaced.

Wiper squeegees exposed to the elements for a long time tend to lose their wiping effectiveness. Periodic cleaning of the squeegees is suggested to remove deposits of salt and road film. The wiper blades, arms, and windshield or rear glass should be cleaned with a sponge or cloth and windshield washer fluid, a mild detergent, or a non-abrasive cleaner. If the squeegees continue to streak or smear, the wiper blades should be replaced.

The blades are mounted to spring-loaded wiper arms. The spring tension of the wiper arms controls the pressure applied to the blades on the glass. The windshield wiper arms are secured by a nut to each of the two wiper pivots that protrude through the cowl plenum cover/grille panel at the base of the windshield. The rear wiper arm is secured by a nut directly to the rear wiper motor output shaft on the liftgate below the rear window glass.

The wiper arms and blades cannot be adjusted or repaired. If faulty or damaged, they must be replaced.

WIPER LINKAGE AND PIVOT

The wiper linkage and pivot module is secured with four screws through four rubber grommet-type insulators to the cowl plenum panel beneath the cowl plenum cover/grille panel. The wiper motor is secured with screws near the center of the tubular linkage and pivot module bracket, and the wiper pivots are secured to the ends of the module bracket.

The two wiper pivot crank arms and the wiper motor crank arm each have ball studs on their ends. The motor crank arm ball stud is the longer of the three. Two drive links connect the motor crank arm to the pivot crank arms.

The passenger side drive link has a plastic socket-type bushing on each end. The driver side drive link has a plastic socket-type bushing on one end, and a plastic sleeve-type bushing on the other end. The socket-type bushing on one end of each drive link is snap-fit over the ball stud on the crank arm of its respective pivot. The driver side drive link sleeve-type bushing end is then fit over the motor crank arm ball stud, and the second socket-type bushing of the passenger side drive link is snap-fit over the exposed end of the motor crank arm ball stud.

The wiper linkage, pivots, bushings, mounting bracket, and motor are only serviced as a complete unit. If any part of this assembly is faulty or damaged, the entire wiper module must be replaced.

DESCRIPTION AND OPERATION (Continued)

WIPER MOTOR

FRONT

The two-speed permanent magnet wiper motor has an integral transmission and park switch. The motor also contains an internal automatic resetting circuit breaker to protect the motor from overloads.

The motor is secured near the center of the tubular wiper linkage and pivot module bracket with three screws. The wiper motor output shaft passes through a hole in the module bracket, where a nut secures the wiper motor crank arm to the motor output shaft.

Wiper speed is controlled by current flow to the proper set of brushes. The wiper motor completes its wipe cycle when the windshield wiper switch on the end of the multi-function switch stalk is turned to the Off position, and parks the blades in the lowest portion of the wipe pattern.

The windshield wiper linkage, pivots, bushings, mounting bracket, and motor are only serviced as a complete unit. If any part of this unit is faulty or damaged, the entire wiper module must be replaced.

REAR

The rear wiper motor is secured to a bracket that is fastened to the liftgate inner panel with two screws through two rubber grommet-type insulators, below the rear window glass and behind the liftgate trim panel. The motor output shaft passes through the liftgate outer panel where a rubber grommet and a nut seal and secure the unit to the liftgate outer panel. A plastic cover snaps onto the motor output shaft to conceal the mounting nut. The rear wiper arm is secured directly to the motor output shaft with another nut, which is also concealed by a plastic cover that snaps onto the end of the wiper arm.

The rear wiper motor unit provides a single speed intermittent-cycle operating mode, which is provided by an electronic timer circuit that is integral to the motor unit. The rear wiper motor cannot be repaired. If faulty or damaged, the entire rear wiper motor assembly must be replaced.

WIPER SWITCH AND WASHER SWITCH

FRONT

The windshield wiper and washer switches are contained in the multi-function switch assembly (Fig. 1). The multi-function switch assembly is secured to the left side of the steering column. A knob on the end of the multi-function switch stalk is rotated to select the desired wiper speed or intermittent wipe delay, or depressed toward the steering column to activate the washer system.

The multi-function switch contains circuitry for the following functions:

- Turn signals
- Hazard warning
- Headlamp beam selection
- Headlamp optical horn
- Windshield wipers
- Windshield washers.

The information contained in this group addresses only the switch functions for the windshield wiper and washer systems. For information relative to the other switch functions, refer to the proper group. However, the multi-function switch cannot be repaired. If any function of the multi-function switch is faulty, or if the switch is damaged, the entire switch assembly must be replaced.

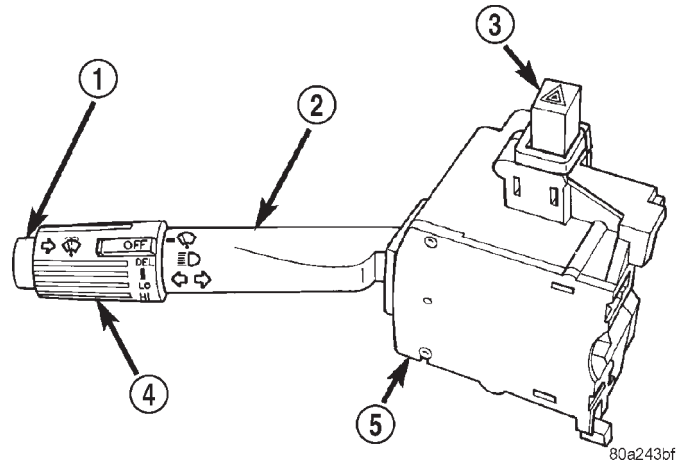

Fig. 1 Multi-Function Switch

- 1 - WINDSHIELD WASHER BUTTON
- 2 - CONTROL STALK
- 3 - HAZARD WARNING BUTTON
- 4 - WINDSHIELD WIPER CONTROL
- 5 - MULTI-FUNCTION SWITCH

REAR

The single two-function rear wiper and washer switch is integral to the rear window switch pod, which includes the rear window defogger switch. The rear window switch pod is installed in the instrument panel lower bezel, which is located near the center of the lower instrument panel, below the heater and air conditioner controls. The rear wiper and washer switch controls the rear wiper and washer functions.

The rear window switch pod also contains the rear window defogger logic and timer circuitry, an amber defogger indicator lamp, the rear window defogger relay, and two switch illumination lamps. The indicator and illumination lamps in the switch pod use incandescent bulbs, which can be serviced.

The sliding-type switch features a detent in the On position for the rear wiper. Pushing in on the rear wiper switch button activates the momentary rear washer switch. The rear wiper and washer switch

DESCRIPTION AND OPERATION (Continued)

also has an integral illumination lamp with a serviceable bulb. Both the rear wiper and rear washer motors will operate continuously for as long as the switch is held in the momentary Wash position.

The rear wiper and washer switch cannot be repaired and, if faulty or damaged, the entire rear window switch pod must be replaced.

CENTRAL TIMER MODULE

Two versions of the Central Timer Module (CTM) are available on this vehicle, a base version and a high-line version. The base version of the CTM is used on base models of the vehicle. The base version of the CTM combines the functions of a chime/buzzer module and an intermittent wipe module into a single unit. The base CTM also uses inputs from the door ajar switches, the headlamp switch and the key-in ignition switch to control the output to the dome lamp circuits, which allows the base CTM to provide load shedding to help protect the battery from becoming discharged.

The high-line version of the CTM is used on high-line vehicles. The high-line CTM provides all of the functions of the base version CTM, but also is used to control and integrate many of the additional electronic functions and features included on the high-line models. The high-line version of the CTM contains a central processing unit and interfaces with other modules in the vehicle on the Chrysler Collision Detection (CCD) data bus network.

The CCD data bus network allows the sharing of sensor information. This helps to reduce wire harness complexity, reduce internal controller hardware, and reduce component sensor current loads. At the same time, this system provides increased reliability, enhanced diagnostics, and allows the addition of many new feature capabilities.

Both the base and the high-line versions of the CTM support the intermittent wipe and wipe-after-wash features, but only the high-line CTM supports the speed sensitive intermittent wipe. The intermittent wipe relay is one of the outputs that both the base and the high-line versions of the CTM can control. Each CTM is programmed to energize or de-energize the intermittent wipe relay in response to certain inputs from the windshield wiper and washer switches and from the windshield wiper motor park switch.

For the speed sensitive intermittent wipe feature, the high-line CTM also uses vehicle speed messages, which are received on the CCD data bus from the Powertrain Control Module (PCM). Refer to Group 14 - Fuel Systems for more information on the PCM and the PCM inputs.

Both versions of the CTM are mounted under the passenger side end of the instrument panel, outboard

of the instrument panel glove box opening. Refer to Central Timer Module in the Removal and Installation section of Group 8E - Instrument Panel Systems for the service procedures.

See Wiper System in the Diagnosis and Testing section of this group for diagnosis of the base version of the CTM. For diagnosis of the high-line version of the CTM or the CCD data bus, a DRBIII® scan tool and the proper Diagnostic Procedures manual are recommended. The CTM cannot be repaired and, if faulty or damaged, it must be replaced.

INTERMITTENT WIPE RELAY

The intermittent wipe relay is a International Standards Organization (ISO) micro-relay. The terminal designations and functions are the same as a conventional ISO relay. However, the micro-relay terminal orientation (or footprint) is different, current capacity is lower, and the relay case dimensions are smaller than those of the conventional ISO relay.

The intermittent wipe relay is a electromechanical device that switches battery current to the windshield wiper motor or wiper motor park switch when the relay coil is grounded by the Central Timer Module (CTM) in response to inputs from the windshield wiper (multi-function) switch. See Intermittent Wipe Relay in the Diagnosis and Testing section of this group for more information.

The intermittent wipe relay is located in the Power Distribution Center (PDC), in the engine compartment. Refer to the PDC label for relay identification and location.

The intermittent wipe relay cannot be repaired and, if faulty or damaged, it must be replaced.

WASHER RESERVOIR

The washer fluid reservoir is integral to and located on the right end of the upper radiator shroud in the engine compartment. Both the washer pump and motor unit and the washer fluid level sensor have barbed nipples, which are installed through a rubber grommet seal inserted in holes on the right end of the upper radiator shroud and reservoir unit. The washer pump and washer fluid level sensor are retained by an interference fit between the barbed nipple and the grommet seal, which is a light press fit.

The washer reservoir has a snap-fit filler cap with a rubber gasket. The cap hinges on and is secured to a molded-in hook formation on the top of the fan shroud, just inboard of the reservoir filler neck. The washer reservoir grommet seals and filler cap are each available for service. The washer reservoir is serviced only as a unit with the upper radiator shroud. Refer to Group 7 - Cooling System for the upper radiator shroud service procedures.

DESCRIPTION AND OPERATION (Continued)

WASHER PUMP

The washer pumps and motors are mounted on the right end of the upper radiator shroud near the bottom of the washer reservoir. A barbed nipple on the pump housing passes through a rubber grommet seal installed in a hole near the bottom of the reservoir. The washer pump is retained by an interference fit between the barbed pump nipple and the grommet seal, which is a light press fit.

A permanently lubricated and sealed motor is coupled to a rotor-type pump. Washer fluid is gravity-fed from the reservoir to the pump. When the motor is energized, the pump pressurizes the washer fluid and forces it through the plumbing to the nozzles.

The washer pump and motor units cannot be repaired. If faulty, the entire washer pump and motor unit must be replaced.

WASHER FLUID LEVEL SENSOR

The standard washer fluid level sensor is mounted on the right outboard end of the upper radiator shroud near the front of the windshield washer reservoir. A barbed nipple on the sensor is press-fit into a rubber grommet seal installed in a hole in the side of the reservoir.

When the fluid level in the reservoir falls below the pivoting float on the sensor, the float changes position and closes the internal switch contacts of the sensor. Refer to Low Washer Fluid Warning Lamp in the Diagnosis and Testing section of Group 8E - Instrument Panel Systems for diagnosis of the low washer fluid warning lamp and circuit, including the sensor.

The washer fluid level sensor cannot be repaired. If faulty or damaged, the sensor unit must be replaced.

WASHER NOZZLE AND PLUMBING**FRONT**

Pressurized washer fluid is fed through a single hose, attached to a barbed nipple on the washer pump. The hose is routed from the washer reservoir to the dash panel along the top of the right front wheelhouse inner panel. At the dash panel, the hose passes through a grommet inserted in a hole in the cowl plenum panel to an in-line fitting located in the cowl plenum area, beneath the cowl plenum cover/grille panel.

A hose from the in-line fitting in the cowl plenum is routed through clips molded into the underside of the cowl plenum cover/grille panel to a wye fitting near the passenger side washer nozzle. Hoses from the wye fitting are routed to the two washer nozzles, which are snap-fit into openings in the cowl plenum cover/grille panel.

The wye fitting includes an integral check valve to prevent the washer fluid from draining from the nozzles back to the reservoir or from leaking out of the nozzles after washer operation is complete. The two fluidic washer nozzles are not adjustable. The nozzles and hose fittings cannot be repaired and, if faulty or damaged, they must be replaced.

REAR

Pressurized washer fluid is fed through a single hose, attached to a barbed nipple on the rear window washer pump. The hose is routed from the washer reservoir to the dash panel along the top of the right front wheelhouse inner panel. At the dash panel, the hose passes through a grommet in the dash panel into the passenger compartment. Inside the passenger compartment the hose is routed down the right cowl side inner panel to the sill, then along the sill to the right quarter inner panel. The hose is routed along the quarter inner panel and up the right liftgate opening pillar to the liftgate opening header.

Located near the top of the supply hose routing, beneath the right liftgate opening pillar trim, the hose connects to a check valve. The check valve prevents washer fluid drain-back or siphoning from occurring. From the check valve, another single hose is routed to the liftgate opening header panel. There the hose passes through a grommet out of the liftgate opening header and through another grommet into the top of the liftgate inner panel. Within the liftgate, the hose is connected to a nipple that protrudes from the fluidic washer nozzle, which is snap-fit into a keyed hole in the top of the liftgate outer panel.

The rear window washer nozzle cannot be adjusted. The nozzle, check valve, and hose fittings cannot be repaired and, if faulty or damaged, they must be replaced.

DIAGNOSIS AND TESTING**WIPER SYSTEM****FRONT**

If the problem being diagnosed involves only the pulse wipe or wipe-after-wash modes, see Washer System in the Diagnosis and Testing section of this group. For circuit descriptions and diagrams, refer to 8W-53 - Wipers in Group 8W - Wiring Diagrams.

DIAGNOSIS AND TESTING (Continued)

WARNING: ON VEHICLES EQUIPPED WITH AIR-BAGS, REFER TO GROUP 8M - PASSIVE RESTRAINT SYSTEMS BEFORE ATTEMPTING ANY STEERING WHEEL, STEERING COLUMN, OR INSTRUMENT PANEL COMPONENT DIAGNOSIS OR SERVICE. FAILURE TO TAKE THE PROPER PRECAUTIONS COULD RESULT IN ACCIDENTAL AIR-BAG DEPLOYMENT AND POSSIBLE PERSONAL INJURY.

(1) Check the fuse in the junction block. If OK, go to Step 2. If not OK, repair the shorted circuit or component as required and replace the faulty fuse.

(2) Turn the ignition switch to the On position. Check for battery voltage at the fuse in the junction block. If OK, go to Step 3. If not OK, repair the open circuit to the ignition switch as required.

(3) Turn the ignition switch to the Off position. Disconnect and isolate the battery negative cable. Unplug the multi-function switch wire harness connector. Connect the battery negative cable. Turn the ignition switch to the On position. Check for battery voltage at the fused ignition switch output (run/accessory) circuit cavity of the multi-function switch wire harness connector. If OK, go to Step 4. If not OK, repair the open circuit to the fuse in the junction block as required.

(4) If the problem being diagnosed involves only the intermittent wipe feature, go to Step 5. If the problem being diagnosed involves all wiper modes, or only the Low and/or High speed modes, go to Step 7.

(5) Turn the ignition switch to the Off position. Disconnect and isolate the battery negative cable. Move the Central Timer Module (CTM) from its mounting position far enough so that the CTM wire harness connectors can be accessed. Refer to Central Timer Module in the Removal and Installation section of Group 8E - Instrument Panel Systems for the procedures. Unplug the 14-way CTM wire harness connector. Check for continuity between the wiper switch mode sense circuit cavities of the multi-function switch wire harness connector and the CTM 14-way wire harness connector. There should be continuity. If OK, go to Step 6. If not OK, repair the open circuit as required.

(6) Check for continuity between the windshield wiper switch signal circuit cavities of the multi-function switch wire harness connector and the CTM 14-way wire harness connector. There should be continuity. If OK, see Intermittent Wipe Relay in the Diagnosis and Testing section of this group. If not OK, repair the open circuit as required.

(7) Check for continuity between the two wiper switch low speed output circuit cavities of the multi-function switch wire harness connector. There should be continuity. If OK, go to Step 8. If not OK, repair the open circuit as required.

(8) Test the wiper switch. See Wiper Switch and Washer Switch in the Diagnosis and Testing section of this group for the procedures. If the switch tests OK, plug in the multi-function switch wire harness connector and go to Step 9. If not OK, replace the faulty switch and test the wiper system operation. If still not OK, go to Step 9.

(9) Turn the ignition switch to the Off position. Disconnect and isolate the battery negative cable. Move the wiper module far enough to access the wiper motor wire harness connector. Measure the resistance between the ground circuit cavity of the wiper motor wire harness connector and a good ground. The meter should read zero ohms. If OK, go to Step 10. If not OK, repair the circuit to ground as required.

(10) Connect the battery negative cable. Turn the ignition switch to the On position. Place the multi-function switch in the positions indicated in the tests below, and check for battery voltage at the wiper motor wire harness connector.

(a) Check for battery voltage at the fused ignition switch output (run/accessory) circuit cavity of the wiper motor wire harness connector with the wiper switch in any position. If OK, go to Step b. If not OK, repair the open circuit as required.

(b) Check for battery voltage at the wiper switch low speed output circuit cavity of the wiper motor wire harness connector with the wiper switch in the Low position. If OK, go to Step c. If not OK, repair the open circuit as required.

(c) Check for battery voltage at the wiper switch high speed output circuit cavity of the wiper motor wire harness connector with the wiper switch in the High position. If OK, go to Step d. If not OK, repair the open circuit as required.

(d) Check for battery voltage at the wiper park switch sense circuit cavity of the wiper motor wire harness connector with the wiper switch in the Low or High position, then move the switch to the Off position. The meter should switch between battery voltage and zero volts while the wipers are cycling. The meter should read battery voltage when the switch is moved to the Off position until the wipers park, and then read a steady zero volts. If not OK, replace the faulty wiper motor.

REAR

If the problem being diagnosed involves only the rear wipe-after-wash mode, check the rear washer motor control circuit between the rear washer motor wire harness connector and the rear wiper motor wire harness connector for shorts or opens. If the circuit checks OK, replace the faulty rear wiper motor. For circuit descriptions and diagrams, refer to 8W-53 - Wipers in Group 8W - Wiring Diagrams.

DIAGNOSIS AND TESTING (Continued)

WARNING: ON VEHICLES EQUIPPED WITH AIR-BAGS, REFER TO GROUP 8M - PASSIVE RESTRAINT SYSTEMS BEFORE ATTEMPTING ANY STEERING WHEEL, STEERING COLUMN, OR INSTRUMENT PANEL COMPONENT DIAGNOSIS OR SERVICE. FAILURE TO TAKE THE PROPER PRECAUTIONS COULD RESULT IN ACCIDENTAL AIR-BAG DEPLOYMENT AND POSSIBLE PERSONAL INJURY.

(1) Check the fuses in the junction block. If OK, go to Step 2. If not OK, repair the shorted circuit or component as required and replace the faulty fuse(s).

(2) Disconnect and isolate the battery negative cable. Remove the instrument panel lower bezel and unplug the wire harness connector from the rear window switch pod. Connect the battery negative cable. Turn the ignition switch to the On position. Check for battery voltage at the fused ignition switch output (run) circuit cavity of the rear window switch pod wire harness connector. If OK, go to Step 3. If not OK, repair the open circuit to the junction block as required.

(3) Turn the ignition switch to the Off position. Disconnect and isolate the battery negative cable. Check for continuity between the ground circuit cavity of the rear window switch pod wire harness connector and a good ground. There should be continuity. If OK, go to Step 4. If not OK, repair the open circuit to ground as required.

(4) Test the rear wiper and washer switch continuity. See Wiper Switch and Washer Switch in the Diagnosis and Testing section of this group for the procedures. If OK, go to Step 5. If not OK, replace the faulty rear window switch pod.

(5) Remove the liftgate trim panel and unplug the rear wiper motor wire harness connector. Connect the battery negative cable. Check for battery voltage at the fused B(+) circuit cavity of the rear wiper motor wire harness connector. If OK, go to Step 6. If not OK, repair the open circuit to the junction block as required.

(6) Turn the ignition switch to the Off position. Disconnect and isolate the battery negative cable. Check for continuity between the ground circuit cavity of the rear wiper motor wire harness connector and a good ground. There should be continuity. If OK, go to Step 7. If not OK, repair the open circuit to ground as required.

(7) Check for continuity between the rear wiper motor control circuit cavity of the rear wiper motor wire harness connector and a good ground. There should be no continuity. If OK, go to Step 8. If not OK, repair the short circuit as required.

(8) Check for continuity between the rear wiper motor control circuit cavities of the rear wiper motor wire harness connector and the rear window switch

pod wire harness connector. There should be continuity. If OK, replace the faulty rear wiper motor. If not OK, repair the open circuit as required.

WASHER SYSTEM

FRONT

The diagnosis found here addresses an inoperative washer pump or wipe-after-wash feature. If the washer pump operates, but no washer fluid is emitted from the washer nozzles, be certain to check the fluid level in the reservoir. Check for ice or other foreign material in the reservoir, and for pinched, disconnected, broken, or incorrectly routed washer system plumbing. For circuit descriptions and diagrams, refer to 8W-53 - Wipers in Group 8W - Wiring Diagrams.

WARNING: ON VEHICLES EQUIPPED WITH AIR-BAGS, REFER TO GROUP 8M - PASSIVE RESTRAINT SYSTEMS BEFORE ATTEMPTING ANY STEERING WHEEL, STEERING COLUMN, OR INSTRUMENT PANEL COMPONENT DIAGNOSIS OR SERVICE. FAILURE TO TAKE THE PROPER PRECAUTIONS COULD RESULT IN ACCIDENTAL AIR-BAG DEPLOYMENT AND POSSIBLE PERSONAL INJURY.

(1) Turn the ignition switch to the On position. Turn the wiper switch to the Low or High speed position. Check whether the wipers operate. If OK, go to Step 2. If not OK, see Wiper System in the Diagnosis and Testing section of this group.

(2) Turn the wiper switch to the Off position. Depress the washer switch. The washer pump should operate and the wipers should operate for as long as the washer switch is depressed. The wipers should continue to operate for about three sweep cycles after the switch is released before they park. If the wipers are OK, but the washers are not, go to Step 3. If the washers are OK, but the wipers are not, go to Step 5.

(3) Turn the ignition switch to the Off position. Disconnect and isolate the battery negative cable. Unplug the washer pump wire harness connector. Measure the resistance between the ground circuit cavity of the washer pump wire harness connector and a good ground. The meter should read zero ohms. If OK, go to Step 4. If not OK, repair the circuit to ground as required.

(4) Connect the battery negative cable. Turn the ignition switch to the On position. With the washer switch depressed, measure the voltage at the washer switch output circuit cavity of the washer pump wire harness connector. The meter should read battery voltage. If OK, replace the faulty pump. If not OK, repair the open circuit as required.

DIAGNOSIS AND TESTING (Continued)

(5) Turn the ignition switch to the Off position. Disconnect and isolate the battery negative cable. Move the Central Timer Module (CTM) from its mounting position far enough so that the CTM wire harness connectors can be accessed. Refer to Central Timer Module in the Removal and Installation section of Group 8E - Instrument Panel Systems for the procedures. Unplug the 14-way wire harness connector from the CTM. Connect the battery negative cable. Turn the ignition switch to the On position. With the washer switch depressed, check for battery voltage at the washer switch sense circuit cavity of the 14-way CTM wire harness connector. If OK, see Intermittent Wipe Relay in the Diagnosis and Testing section of this group. If not OK, repair the open circuit as required.

REAR

The diagnosis found here addresses an inoperative rear washer pump. If the washer pump operates, but no washer fluid is emitted from the washer nozzle, be certain to check the fluid level in the reservoir. Check for ice or other foreign material in the reservoir, and for pinched, disconnected, broken, or incorrectly routed washer system plumbing. For circuit descriptions and diagrams, refer to 8W-53 - Wipers in Group 8W - Wiring Diagrams.

WARNING: ON VEHICLES EQUIPPED WITH AIRBAGS, REFER TO GROUP 8M - PASSIVE RESTRAINT SYSTEMS BEFORE ATTEMPTING ANY STEERING WHEEL, STEERING COLUMN, OR INSTRUMENT PANEL COMPONENT DIAGNOSIS OR SERVICE. FAILURE TO TAKE THE PROPER PRECAUTIONS COULD RESULT IN ACCIDENTAL AIRBAG DEPLOYMENT AND POSSIBLE PERSONAL INJURY.

(1) Turn the ignition switch to the On position. Place the rear wiper and washer switch in the Wipe position. Check whether the rear wiper is operating. If OK, go to Step 2. If not OK, see Wiper System in the Diagnosis and Testing section of this group.

(2) Turn the ignition switch to the Off position. Disconnect and isolate the battery negative cable. Unplug the rear washer pump wire harness connector. Check for continuity between the ground circuit cavity of the rear washer pump wire harness connector and a good ground. There should be continuity. If OK, go to Step 3. If not OK, repair the open circuit to ground as required.

(3) Connect the battery negative cable. Turn the ignition switch to the On position. Check for battery voltage at the rear washer motor control circuit cavity of the rear washer pump wire harness connector while the rear washer switch is actuated. If OK, replace the faulty pump. If not OK, go to Step 4.

(4) Turn the ignition switch to the Off position. Disconnect and isolate the battery negative cable. Unplug the rear wiper and washer switch wire harness connector. Unplug the wire harness connector at the rear wiper motor. Check for continuity between the rear washer motor control circuit cavity of the rear washer pump wire harness connector and a good ground. There should be no continuity. If OK, go to Step 5. If not OK, repair the short circuit as required.

(5) Check for continuity between the rear washer motor control circuit cavities of the rear washer pump wire harness connector and the rear wiper and washer switch wire harness connector. There should be continuity. If OK, replace the faulty switch. If not OK, repair the open circuit as required.

WIPER SWITCH AND WASHER SWITCH**FRONT**

See Wiper System and/or Washer System in the Diagnosis and Testing section of this group before testing the multi-function switch. For circuit descriptions and diagrams, refer to 8W-53 - Wipers in Group 8W - Wiring Diagrams.

WARNING: ON VEHICLES EQUIPPED WITH AN AIRBAG, REFER TO GROUP 8M - PASSIVE RESTRAINT SYSTEMS BEFORE ATTEMPTING ANY STEERING WHEEL, STEERING COLUMN, OR INSTRUMENT PANEL COMPONENT DIAGNOSIS OR SERVICE. FAILURE TO TAKE THE PROPER PRECAUTIONS COULD RESULT IN ACCIDENTAL AIRBAG DEPLOYMENT AND POSSIBLE PERSONAL INJURY.

(1) Disconnect and isolate the battery negative cable.

(2) Unplug the multi-function switch wire harness connector from the multi-function switch.

(3) Using an ohmmeter, perform the switch continuity checks at the switch terminals as shown in the Multi-Function Switch Continuity chart (Fig. 2).

(4) If the switch fails any of the continuity checks, replace the faulty switch. If the switch is OK, repair the wiper system and/or washer system wire harness circuits as required.

REAR

Perform the diagnosis for the rear wiper system and/or washer system as described in this group before testing the rear wiper and washer switch. For circuit descriptions and diagrams, see 8W-53 - Wipers in Group 8W - Wiring Diagrams.

DIAGNOSIS AND TESTING (Continued)

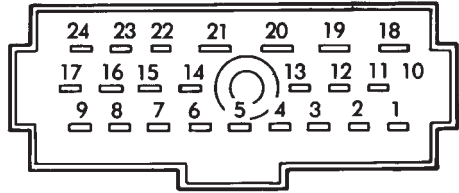

MULTIFUNCTION SWITCH PINS

SWITCH POSITION	CONTINUITY BETWEEN
OFF	PIN 6 AND PIN 7
DELAY	PIN 8 AND PIN 9 PIN 2 AND PIN 4 PIN 1 AND PIN 2 PIN 1 AND PIN 4
LOW	PIN 4 AND PIN 6
HIGH	PIN 4 AND PIN 5
WASH	PIN 3 AND PIN 4
*RESISTANCE AT MAXIMUM DELAY POSITION SHOULD BE BETWEEN 270,000 OHMS AND 330,000 OHMS. *RESISTANCE AT MINIMUM DELAY POSITION SHOULD BE ZERO WITH OHMMETER SET ON HIGH OHM SCALE.	

918J-4

Fig. 2 Multi-Function Switch Continuity

WARNING: ON VEHICLES EQUIPPED WITH AIR-BAGS, REFER TO GROUP 8M - PASSIVE RESTRAINT SYSTEMS BEFORE ATTEMPTING ANY STEERING WHEEL, STEERING COLUMN, OR INSTRUMENT PANEL COMPONENT DIAGNOSIS OR SERVICE. FAILURE TO TAKE THE PROPER PRECAUTIONS COULD RESULT IN ACCIDENTAL AIR-BAG DEPLOYMENT AND POSSIBLE PERSONAL INJURY.

(1) Remove the lower bezel from the instrument panel and unplug the rear window switch pod wire harness connector.

(2) Using an ohmmeter, check the rear wiper and washer switch continuity at the rear window switch pod terminals as shown in the Rear Wiper Switch and Washer Switch Continuity chart (Fig. 3).

(3) If the switch fails any of the continuity checks, replace the faulty rear window switch pod. If the switch is OK, repair the rear wiper system and/or washer system wire harness circuits as required.

INTERMITTENT WIPE RELAY

For circuit descriptions and diagrams, refer to 8W-53 - Wipers in Group 8W - Wiring Diagrams.

WARNING: ON VEHICLES EQUIPPED WITH AIR-BAGS, REFER TO GROUP 8M - PASSIVE RESTRAINT SYSTEMS BEFORE ATTEMPTING ANY STEERING WHEEL, STEERING COLUMN, OR INSTRUMENT PANEL COMPONENT DIAGNOSIS OR SERVICE. FAILURE TO TAKE THE PROPER PRECAUTIONS COULD RESULT IN ACCIDENTAL AIR-

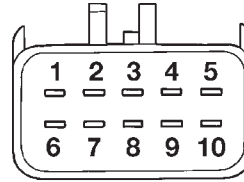

VIEW OF SWITCH SIDE OF SWITCH POD CONNECTOR

REAR WINDOW SWITCH POD	
SWITCH POSITION	CONTINUITY BETWEEN
OFF	3 & 4 (LAMPS)
WIPER SWITCH ON	2 & 7
WASHER SWITCH ON DEPRESSED	7 & 8
LAMPS	3 & 4

80b27ccc

Fig. 3 Rear Wiper Switch and Washer Switch Continuity

BAG DEPLOYMENT AND POSSIBLE PERSONAL INJURY.

RELAY TEST

The intermittent wipe relay (Fig. 4) is located in the Power Distribution Center (PDC) in the engine compartment. Refer to the PDC label for intermittent wipe relay identification and location.

Remove the intermittent wipe relay from the PDC as described in the Removal and Installation section of this group to perform the following tests:

(1) A relay in the de-energized position should have continuity between terminals 87A and 30, and no continuity between terminals 87 and 30. If OK, go to Step 2. If not OK, replace the faulty relay.

(2) Resistance between terminals 85 and 86 (electromagnet) should be 75 ± 5 ohms. If OK, go to Step 3. If not OK, replace the faulty relay.

(3) Connect a battery to terminals 85 and 86. There should now be continuity between terminals 30 and 87, and no continuity between terminals 87A and 30. If OK, see Relay Circuit Test in the Diagnosis and Testing section of this group. If not OK, replace the faulty relay.

DIAGNOSIS AND TESTING (Continued)

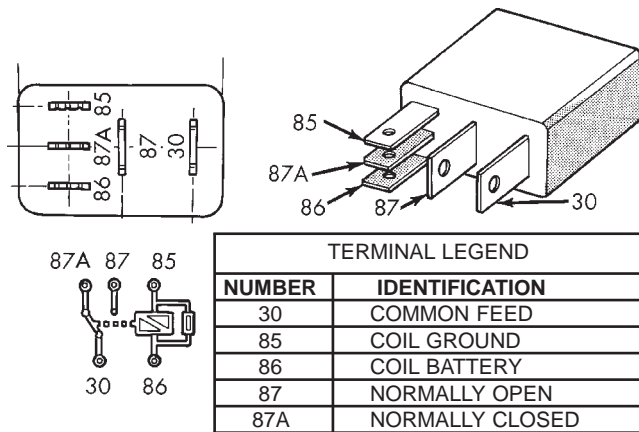

Fig. 4 Intermittent Wipe Relay

RELAY CIRCUIT TEST

(1) The relay common feed terminal cavity (30) is connected to the wiper (multi-function) switch. There should be continuity between the cavity for relay terminal 30 and the two fused ignition switch output circuit cavities of the multi-function switch wire harness connector at all times. If OK, go to Step 2. If not OK, repair the open circuit(s) to the multi-function switch as required.

(2) The relay normally closed terminal (87A) is connected to terminal 30 in the de-energized position. There should be continuity between the cavity for relay terminal 87A and the wiper park switch sense circuit cavities of the wiper motor wire harness connector and the 14-way Central Timer Module (CTM) wire harness connector at all times. If OK, go to Step 3. If not OK, repair the open circuit(s) to the wiper motor and CTM as required.

(3) The relay normally open terminal (87) is connected to the common feed terminal (30) in the energized position. There should be battery voltage at the cavity for relay terminal 87 with the ignition switch in the On or Accessory positions. If OK, go to Step 4. If not OK, repair the open circuit to the ignition switch as required.

(4) The coil battery terminal (86) is connected to the electromagnet in the relay. There should be battery voltage at the cavity for relay terminal 86 with the ignition switch in the On or Accessory positions. If OK, go to Step 5. If not OK, repair the open circuit to the ignition switch as required.

(5) The coil ground terminal (85) is connected to the electromagnet in the relay. It is grounded by the CTM to energize the relay and cycle the wiper motor. Check for continuity between the cavity for relay terminal 85 and the intermittent wiper relay control circuit cavity of the 14-way CTM wire harness connector. There should be continuity. If OK, replace the faulty base version CTM; or, use a DRB scan tool

and the proper Diagnostic Procedures manual for diagnosis of the high-line version CTM. If not OK, repair the open circuit to the CTM as required.

REMOVAL AND INSTALLATION

WIPER BLADE

FRONT

NOTE: The driver side and passenger side wiper blades are not interchangeable. The driver side wiper blade has an extra bridge and eight pairs of claws securing the wiper element. The passenger side wiper blade has six pairs of claws securing the wiper element. The notched retainer end of both wiper elements should always be oriented towards the end of the wiper blade that is nearest to the wiper pivot.

(1) Turn the windshield wiper switch to the On position. By turning the ignition switch to the On and Off positions, cycle the wiper blades to a convenient working location on the windshield.

(2) Lift the wiper arm to raise the wiper blade and element off of the windshield glass.

(3) To remove the wiper blade from the wiper arm, push the release tab under the arm tip and slide the blade away from the tip towards the pivot end of the arm (Fig. 5).

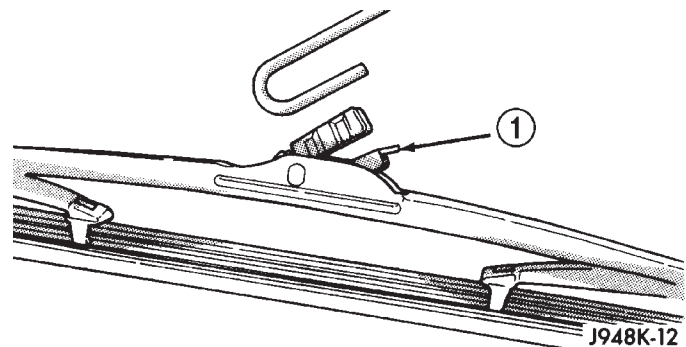

Fig. 5 Windshield Wiper Blade Remove/Install - Typical

1 - RELEASE TAB

(4) To install the wiper blade on the wiper arm, slide the blade retainer into the U-shaped formation on the tip of the wiper arm until the release tab snaps into its locked position. Be certain that the notched retainer for the wiper element is oriented towards the end of the wiper blade that is nearest to the wiper pivot.

REMOVAL AND INSTALLATION (Continued)

REAR

NOTE: The notched retainer end of the wiper element should always be oriented towards the end of the wiper blade that is nearest to the rear wiper motor output shaft.

(1) To remove the wiper blade from the wiper arm, lift up the retainer release tab on the top of the wiper arm to unlatch it from the wiper arm (Fig. 6).

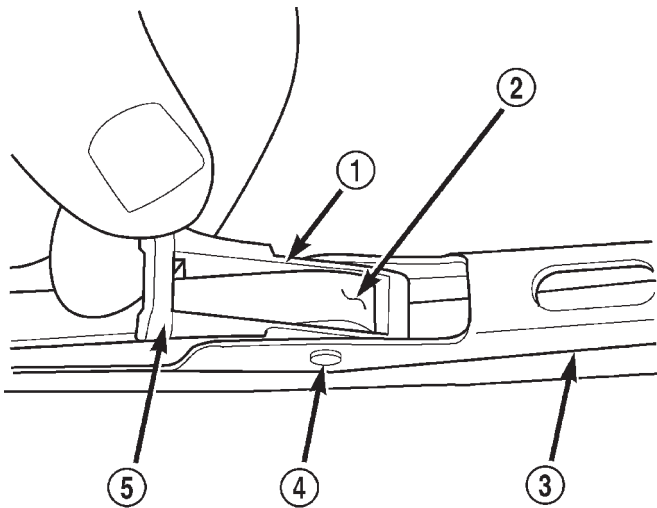

80bce936

Fig. 6 Rear Wiper Blade Remove/Install

- 1 - RETAINER WINDOW
- 2 - TIP OF REAR WIPER ARM
- 3 - REAR WIPER BLADE
- 4 - BLADE PIVOT PIN
- 5 - RETAINER RELEASE TAB

(2) Raise the retainer release tab until it is perpendicular to the rear wiper blade.

(3) Slide the rear wiper blade towards the rear wiper motor output shaft end of the rear wiper arm to disengage the blade retainer pivot from the U-shaped formation on the tip of the wiper arm.

(4) Lift up slightly on the rear wiper arm and slide the rear wiper blade off of the tip of the wiper arm through the retainer window.

(5) To install the rear wiper blade onto the rear wiper arm, lift the rear wiper blade retainer release tab until it is perpendicular to the wiper blade.

(6) Lift up slightly on the rear wiper arm and slide the rear wiper blade retainer window over the U-shaped formation on the tip of the wiper arm. Be certain that the notched retainer for the wiper element is oriented towards the end of the wiper blade that is nearest to the rear wiper motor output shaft.

(7) Release the rear wiper arm and slide the rear wiper blade towards the tip of the wiper arm until the pivot of the blade retainer is engaged in the U-shaped formation on the tip of the wiper arm.

(8) Press down on the rear wiper blade retainer release tab until it snaps into its locked position over the top of the rear wiper arm.

WIPER ARM

CAUTION: The use of a screwdriver or other prying tool to remove a wiper arm may distort it. This distortion could allow the arm to come off of the pivot shaft, regardless of how carefully it is installed.

FRONT

(1) Open the hood of the vehicle.

(2) Carefully pry the plastic nut cap off of the nut on the pivot end of the wiper arm (Fig. 7).

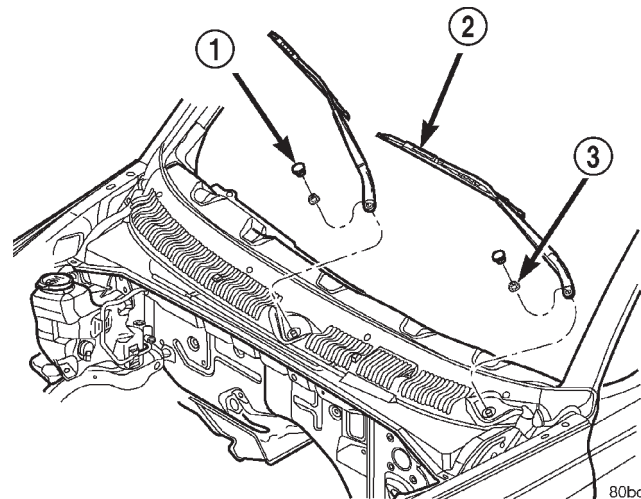

80bce913

Fig. 7 Wiper Arm Remove/Install

- 1 - NUT CAP
- 2 - WIPER ARM AND BLADE
- 3 - NUT

(3) Remove the nut that secures the wiper arm to the wiper pivot.

(4) Use a battery terminal puller to remove the wiper arm from the wiper pivot (Fig. 8).

(5) Install the arm and blade with the wiper motor in the Park position. See the Wiper Arm Installation illustration (Fig. 9).

(6) Mount the arms on the pivot shafts so that the front and rear edges of the wiper blade are aligned with the wiper alignment lines concealed in the upper margin of the lower windshield blackout area, ± 15 mm (± 0.59 in.).

REMOVAL AND INSTALLATION (Continued)

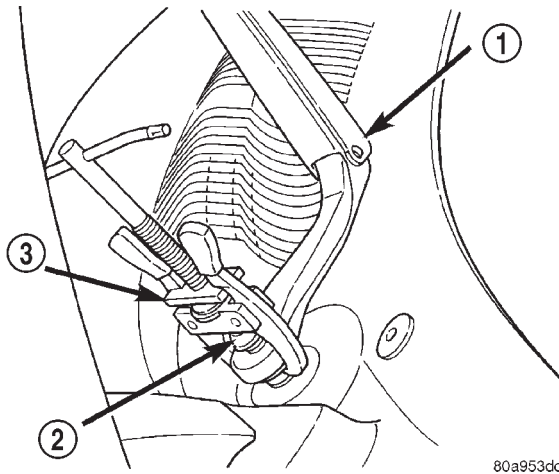
**Fig. 8 Wiper Arm Puller**

- 1 - WIPER ARM
- 2 - WIPER PIVOT
- 3 - BATTERY TERMINAL PULLER

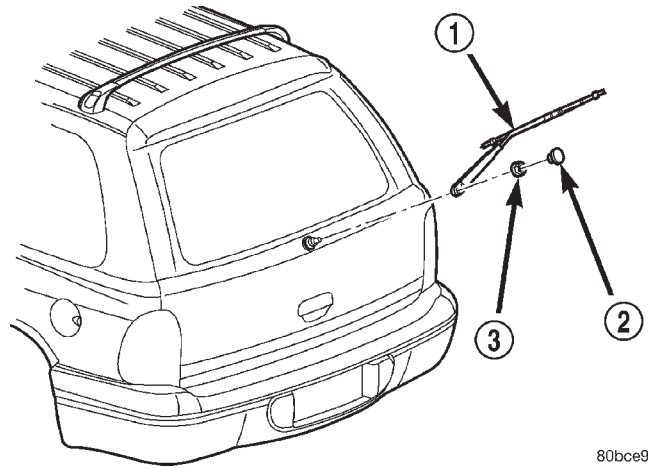
**Fig. 10 Rear Wiper Arm Remove/Install**

- 1 - WIPER ARM AND BLADE
- 2 - NUT CAP
- 3 - NUT

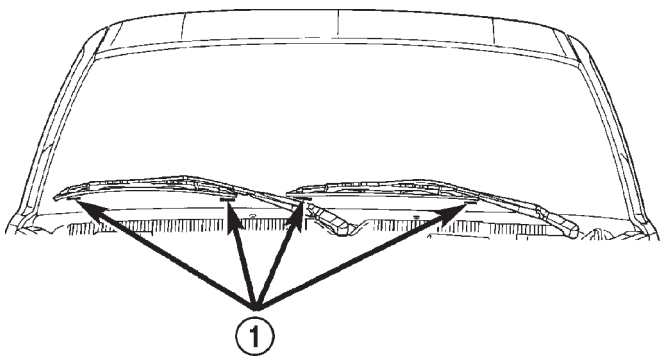
**Fig. 9 Wiper Arm Installation**

- 1 - WIPER ALIGNMENT LINES ± 15 mm (± 0.59 in.)

(7) Install the wiper arm pivot nuts and tighten to 24 N·m (212 in. lbs.).

(8) Operate the wipers with the windshield glass wet, then turn the wiper switch to the Off position. Check for the correct wiper arm positioning and readjust if required.

(9) Install the plastic nut caps onto the wiper arm pivot nuts.

REAR

(1) Carefully pry the plastic nut cap off of the nut on the rear wiper motor output shaft end of the wiper arm (Fig. 10).

(2) Remove the nut that secures the wiper arm to the rear wiper motor output shaft.

(3) Use a battery terminal puller to remove the wiper arm from the wiper pivot (Fig. 8).

(4) Install the arm and blade with the rear wiper motor in the Park position.

(5) Mount the wiper arm on the rear wiper motor output shaft so that the center of the wiper blade is located between the upper margin of the lower rear window blackout area and the lower edge of the trademark on the lower right corner of the rear window glass.

(6) Install the nut that secures the wiper arm to the rear wiper motor output shaft. Tighten the mounting nut to 18 N·m (160 in. lbs.).

(7) Operate the rear wiper with the rear window glass wet, then turn the rear wiper switch to the Off position. Check for the correct wiper arm positioning and readjust if required.

(8) Install the plastic nut cap onto the nut on the rear wiper motor output shaft.

WIPER LINKAGE AND PIVOT

The wiper linkage and pivots can only be removed from or installed in the vehicle as a unit with the wiper motor. See Wiper Motor in the Removal and Installation section of this group for the procedures.

REMOVAL AND INSTALLATION (Continued)

WIPER MOTOR

FRONT

- (1) Disconnect and isolate the battery negative cable.
- (2) Remove the wiper arms from the wiper pivots. See Wiper Arm in the Removal and Installation section of this group for the procedures.
- (3) Remove the weatherstrip along the front edge of the cowl plenum cover/grille panel and the cowl plenum panel (Fig. 11).

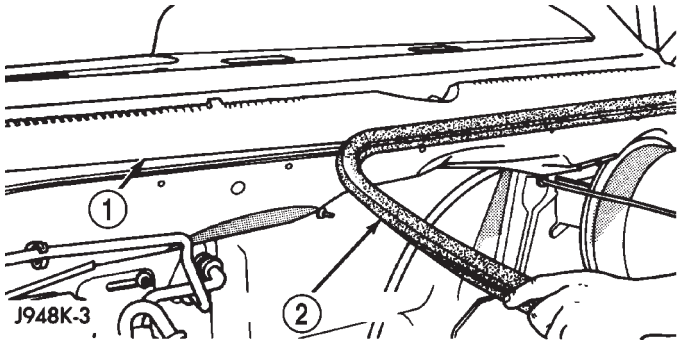

Fig. 11 Cowl Plenum Cover/Grille Panel Weatherstrip

- 1 - COWL GRILLE
- 2 - WEATHERSTRIP

- (4) Remove the four plastic nuts that secure the cowl plenum cover/grille panel to the studs on the cowl top panel near the base of the windshield (Fig. 12).
- (5) Remove the one plastic rivet that secures the front corner on each side of the cowl plenum cover/grille panel to the cowl plenum panel.
- (6) Remove the one plastic push-in retainer that secures the rear corner on each side of the cowl plenum cover/grille panel to the windshield reveal moulding.
- (7) Unsnap the slotted center hole on each side of the cowl plenum cover/grille panel from the adhesive-backed snap fastener. This fastener is secured to the top of each cowl side panel with an adhesive backing, and should not be removed during cowl plenum cover/grille panel removal.
- (8) Lift the cowl plenum cover/grille panel from the cowl top far enough to access the windshield washer nozzle and vacuum plumbing near the right end of the cowl plenum.
- (9) Disconnect the windshield washer supply hose at the in-line connector.
- (10) Disconnect the vacuum supply hose from the vacuum reservoir, which is secured to the underside of the right end of the cowl plenum cover/grille panel (Fig. 13).

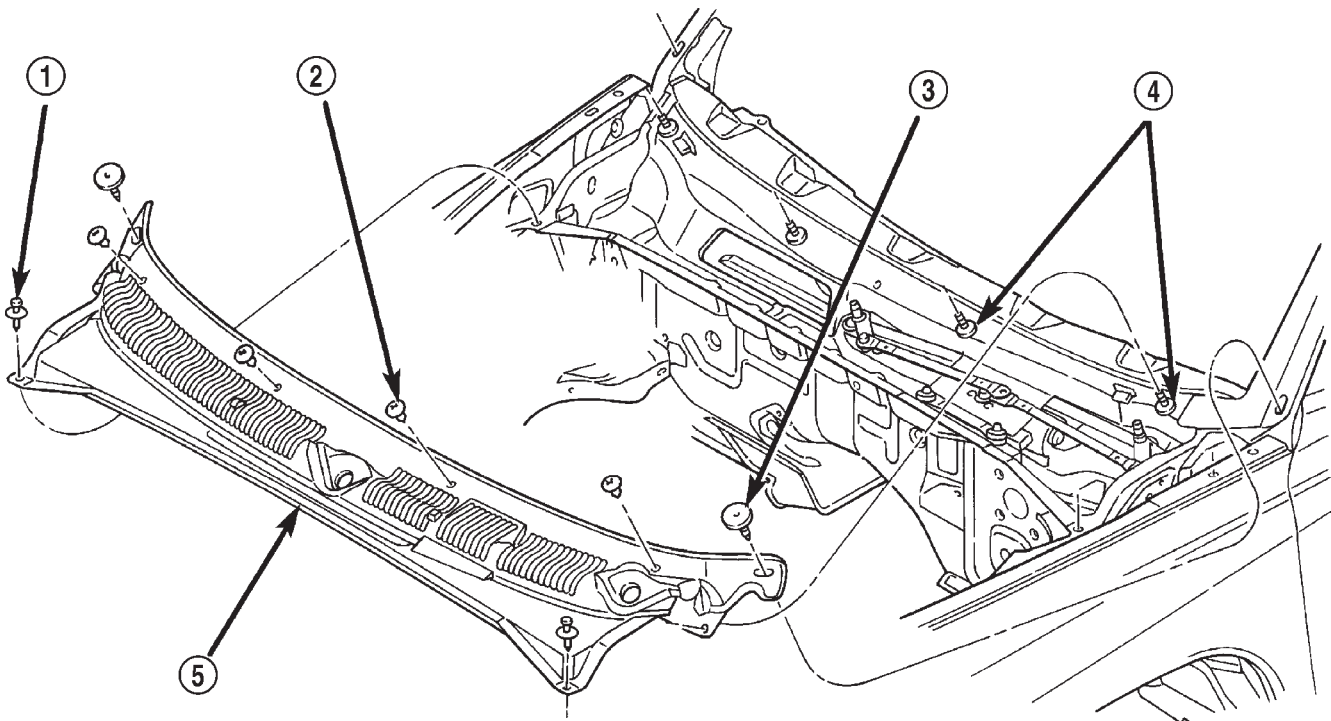
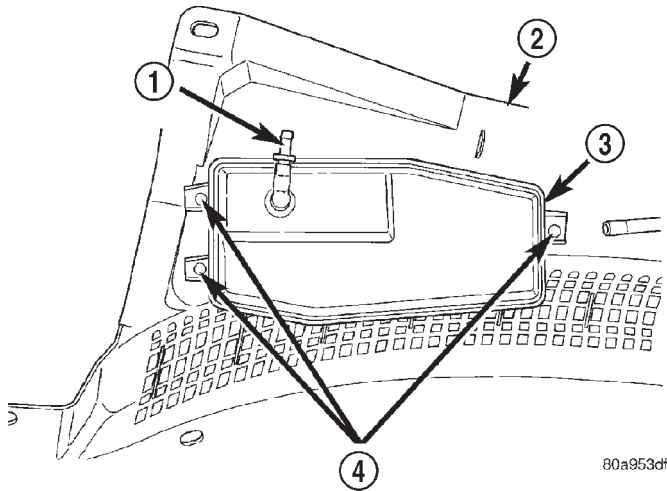

Fig. 12 Cowl Plenum Cover/Grille Panel Remove/Install

- 1 - PLASTIC RIVET (2)
- 2 - PLASTIC NUT (4)
- 3 - PUSH-IN PLASTIC RETAINER (2)
- 4 - STUD (4)
- 5 - COWL PLENUM COVER/GRILLE PANEL

REMOVAL AND INSTALLATION (Continued)

**Fig. 13 Vacuum Reservoir**

- 1 - VACUUM SUPPLY CONNECTOR
- 2 - COWL PLENUM COVER/GRILLE PANEL
- 3 - VACUUM RESERVOIR
- 4 - SCREWS

(11) Remove the cowl plenum cover/grille panel from the vehicle and set it aside.

(12) Remove the four screws that secure the wiper module to the cowl plenum panel (Fig. 14).

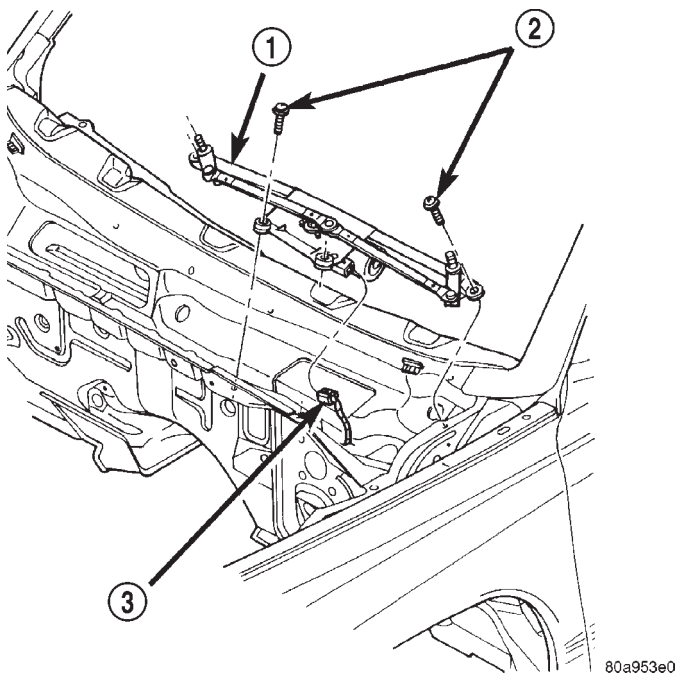
**Fig. 14 Wiper Module Remove/Install**

- 1 - WIPER MODULE
- 2 - SCREWS
- 3 - CONNECTOR

(13) Move the wiper module as required to access the wiper motor wire harness connector.

(14) Unplug the wiper motor wire harness connector from the wiper motor.

(15) Remove the wiper module from the cowl plenum.

(16) Reverse the removal procedures to install. Be certain that the washer nozzle hoses are correctly routed and installed in the retainers on the underside of the cowl plenum cover/grille panel. Tighten the mounting screws to 8 N-m (72 in. lbs.).

REAR

(1) Disconnect and isolate the battery negative cable.

(2) From the outside of the liftgate, remove the rear wiper arm from the rear wiper motor output shaft. See Wiper Arm in the Removal and Installation section of this group for the procedures.

(3) Use a door trim panel removal tool to gently pry at the base of the nut cover where it meets the wiper motor output shaft bezel and grommet on the outer liftgate panel until it unsnaps from the rear wiper motor output shaft (Fig. 15). Be certain to use proper caution to protect the outer liftgate panel and its paint finish from damage during this procedure.

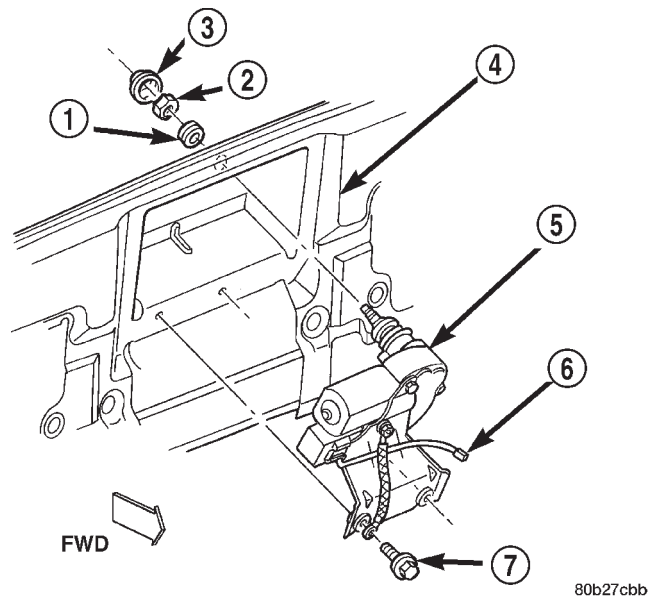
**Fig. 15 Rear Wiper Motor Remove/Install**

- 1 - BEZEL AND GROMMET
- 2 - NUT
- 3 - NUT COVER
- 4 - LIFTGATE INNER PANEL
- 5 - REAR WIPER MOTOR
- 6 - WIRE HARNESS CONNECTOR
- 7 - SCREW

REMOVAL AND INSTALLATION (Continued)

- (4) Remove the nut that secures the rear wiper motor output shaft to the outer liftgate panel.
- (5) Pull the bezel and grommet off of the rear wiper motor output shaft.
- (6) Remove the liftgate trim panel from the liftgate. Refer to Group 23 - Body for the procedures.
- (7) Unplug the rear wiper motor wire harness connector.
- (8) While supporting the wiper motor with a free hand, remove the two screws that secure the rear wiper motor mounting bracket to the liftgate inner panel.
- (9) Remove the rear wiper motor and mounting bracket from the liftgate as a unit.
- (10) When reinstalling the rear wiper motor to the liftgate, first position the motor and bracket to the liftgate inner panel and secure it by loosely installing the mounting screws.
- (11) From the outside of the liftgate, center the rear wiper motor output shaft in the liftgate outer panel mounting hole and secure it with the shaft retaining nut. Tighten the nut to 4.8 N·m (43 in. lbs.).
- (12) Reverse the remaining removal procedures to complete the installation. Tighten the rear wiper motor mounting bracket screws to 8.1 N·m (72 in. lbs.).

INTERMITTENT WIPE RELAY

- (1) Disconnect and isolate the battery negative cable.
- (2) Remove the cover from the Power Distribution Center (PDC) (Fig. 16).

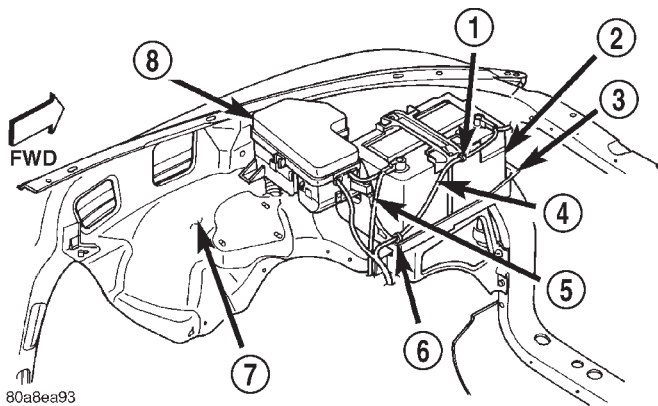

Fig. 16 Power Distribution Center

- 1 - CLIP
- 2 - BATTERY
- 3 - TRAY
- 4 - NEGATIVE CABLE
- 5 - POSITIVE CABLE
- 6 - CLIP
- 7 - FENDER INNER SHIELD
- 8 - POWER DISTRIBUTION CENTER

- (3) Refer to the label on the PDC cover for intermittent wipe relay identification and location.
- (4) Unplug the intermittent wipe relay from the PDC.
- (5) Install the intermittent wipe relay by aligning the relay terminals with the cavities in the PDC and pushing the relay firmly into place.
- (6) Install the PDC cover.
- (7) Connect the battery negative cable.
- (8) Test the relay operation.

WIPER SWITCH AND WASHER SWITCH

FRONT

WARNING: ON VEHICLES EQUIPPED WITH AIR-BAGS, REFER TO GROUP 8M - PASSIVE RESTRAINT SYSTEMS BEFORE ATTEMPTING ANY STEERING WHEEL, STEERING COLUMN, OR INSTRUMENT PANEL COMPONENT DIAGNOSIS OR SERVICE. FAILURE TO TAKE THE PROPER PRECAUTIONS COULD RESULT IN ACCIDENTAL AIR-BAG DEPLOYMENT AND POSSIBLE PERSONAL INJURY.

- (1) Disconnect and isolate the battery negative cable.
- (2) If the vehicle is so equipped, remove the tilt steering column lever.
- (3) Remove both the upper and lower shrouds from the steering column (Fig. 17).
- (4) Remove the lower fixed column shroud.
- (5) Move the upper fixed column shroud far enough to access the rear of the multi-function switch (Fig. 18).
- (6) Remove the tamper proof mounting screws (a Snap On tamper proof torx bit TTXR20B2 or equivalent is required) that secure the multi-function switch to the steering column.
- (7) Gently pull the switch away from the steering column far enough to access and remove the multi-function switch wire harness connector screw.
- (8) Unplug the wire harness connector from the multi-function switch.
- (9) Reverse the removal procedures to install. Tighten the fasteners as follows:
 - Multi-function switch wire harness connector screw - 2 N·m (17 in. lbs.)
 - Multi-function switch mounting screws - 2 N·m (17 in. lbs.).

REMOVAL AND INSTALLATION (Continued)

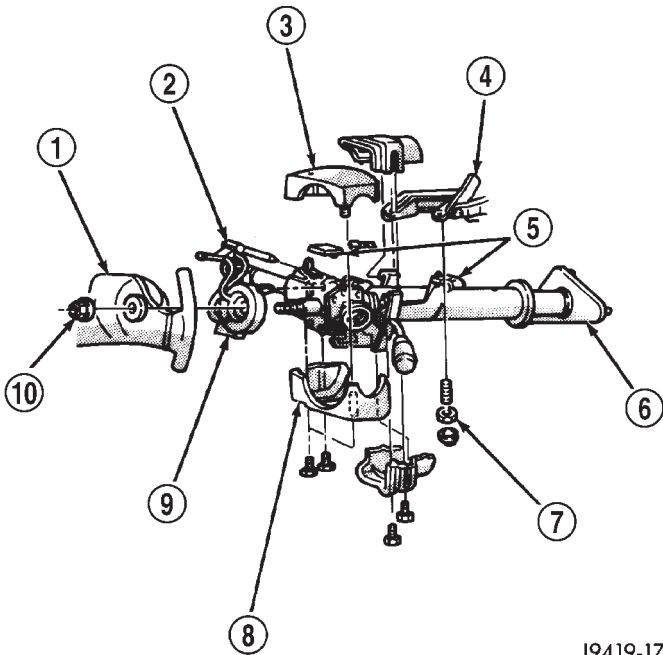

J9419-17

Fig. 17 Steering Column Shrouds Remove/Install - Typical

- 1 - STEERING WHEEL
- 2 - TILT LEVER
- 3 - UPPER SHROUD
- 4 - PANEL BRACKET
- 5 - SPACER
- 6 - TOE PLATE
- 7 - NUT
- 8 - LOWER SHROUD
- 9 - CLOCK SPRING
- 10 - NUT

REAR

WARNING: ON VEHICLES EQUIPPED WITH AIR-BAGS, REFER TO GROUP 8M - PASSIVE RESTRAINT SYSTEMS BEFORE ATTEMPTING ANY STEERING WHEEL, STEERING COLUMN, OR INSTRUMENT PANEL COMPONENT DIAGNOSIS OR SERVICE. FAILURE TO TAKE THE PROPER PRECAUTIONS COULD RESULT IN ACCIDENTAL AIR-BAG DEPLOYMENT AND POSSIBLE PERSONAL INJURY.

- (1) Disconnect and isolate the battery negative cable.
- (2) Remove the lower bezel from the instrument panel. Refer to Instrument Panel Lower Bezel in the Removal and Installation section of Group 8E - Instrument Panel Systems for the procedures.
- (3) Remove the two screws that secure the rear window switch pod to the instrument panel lower bezel (Fig. 19).

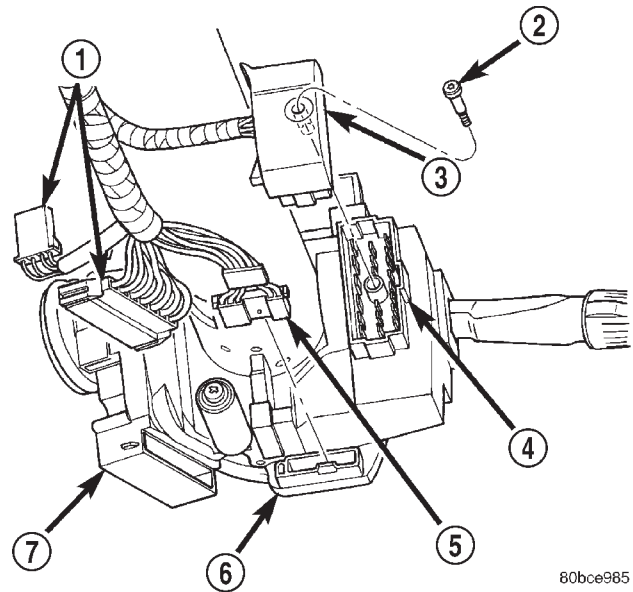

80bce985

Fig. 18 Multi-Function Switch Connector

- 1 - WIRE HARNESS CONNECTORS
- 2 - SCREW
- 3 - WIRE HARNESS CONNECTOR
- 4 - MULTI-FUNCTION SWITCH
- 5 - WIRE HARNESS CONNECTOR
- 6 - CLOCKSPrING
- 7 - IGNITION SWITCH

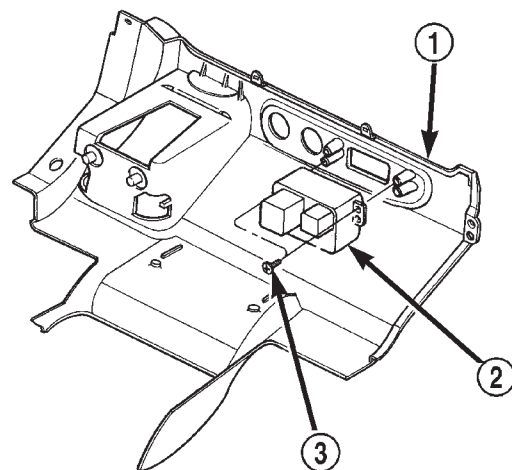

80b27cc1

Fig. 19 Rear Window Switch Pod Remove/Install

- 1 - INSTRUMENT PANEL LOWER BEZEL
- 2 - REAR WINDOW SWITCH POD
- 3 - SCREWS (2)
- (4) Remove the rear window switch pod from the instrument panel lower bezel.
- (5) Reverse the removal procedures to install. Tighten the mounting screws to 2.2 N·m (20 in. lbs.).

REMOVAL AND INSTALLATION (Continued)

WASHER SYSTEM

WASHER RESERVOIR

The washer reservoir is integral to the right end of the upper radiator shroud in the engine compartment (Fig. 20). Refer to Group 7 - Cooling System for the proper upper radiator shroud service procedures.

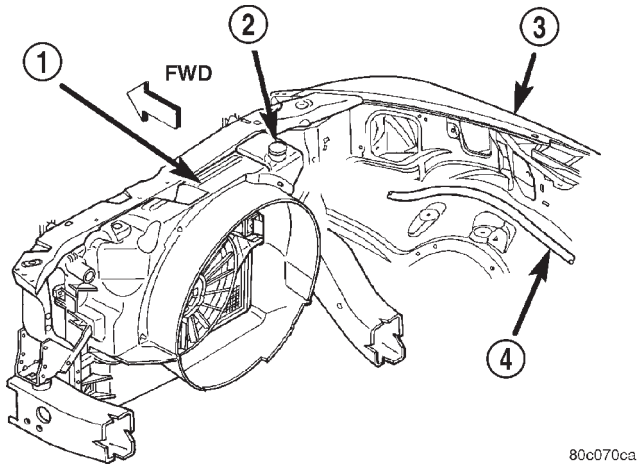

Fig. 20 Washer Reservoir Remove/Install

- 1 - UPPER RADIATOR SHROUD
- 2 - WASHER RESERVOIR FILLER CAP
- 3 - RIGHT FRONT FENDER
- 4 - WASHER SUPPLY HOSE

WASHER PUMP

(1) Disconnect and isolate the battery negative cable.

(2) Disconnect the headlamp and dash wire harness connector from the connector receptacle on the front or rear washer pump (Fig. 21).

(3) Disconnect the washer supply hose from the outlet nipple of the front or rear washer pump. Drain the washer fluid from the reservoir into a clean container for reuse.

(4) Using a trim stick or another suitable wide flat-bladed tool, gently pry the barbed inlet nipple of the washer pump out of the rubber grommet seal in the reservoir. Care must be taken not to damage the reservoir.

(5) Remove the rubber grommet seal from the reservoir and discard.

(6) Reverse the removal procedures to install. Always use a new rubber grommet seal in the washer reservoir.

WASHER FLUID LEVEL SENSOR

(1) Disconnect and isolate the battery negative cable.

(2) Disconnect the headlamp and dash wire harness connector from the connector receptacle on the washer fluid level sensor (Fig. 21).

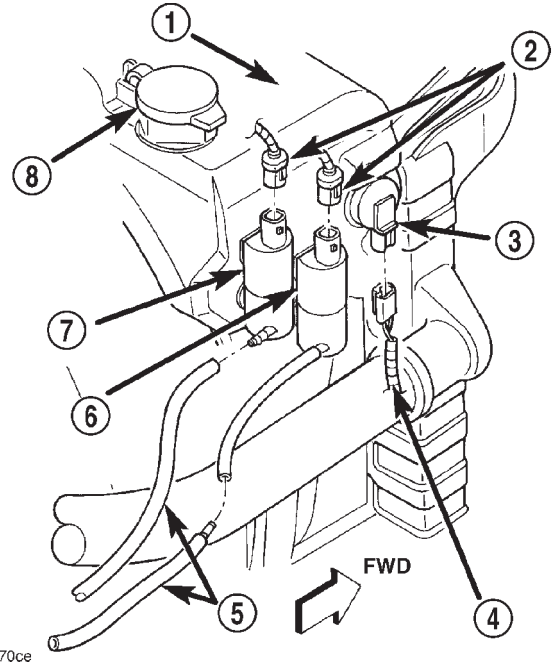

80c070ce

Fig. 21 Washer Pump and Washer Fluid Level Sensor Remove/Install

- 1 - UPPER RADIATOR SHROUD
- 2 - WIRE HARNESS CONNECTORS
- 3 - WASHER FLUID LEVEL SENSOR
- 4 - WIRE HARNESS CONNECTOR
- 5 - WASHER SUPPLY HOSE
- 6 - REAR WASHER PUMP
- 7 - FRONT WASHER PUMP
- 8 - WASHER RESERVOIR FILLER CAP

(3) Disconnect the washer supply hose from the outlet nipple of the front washer pump. Drain the washer fluid from the reservoir into a clean container for reuse.

NOTE: The pivoting float of the washer fluid sensor must be in a horizontal position within the reservoir in order to be removed. With the reservoir empty and held in an upright position, the pivoting float will orient itself to the horizontal position when the sensor connector receptacle is pointed straight downwards.

(4) Using a trim stick or another suitable wide flat-bladed tool, gently pry the washer fluid level sensor out of the rubber grommet seal. Care must be taken not to damage the reservoir.

(5) Remove the rubber grommet seal from the reservoir and discard.

(6) Reverse the removal procedures to install. Always use a new rubber grommet seal in the washer reservoir.

REMOVAL AND INSTALLATION (Continued)

WASHER NOZZLE

FRONT

(1) Remove the cowl plenum cover/grille panel from the cowl top. See Wiper Motor in the Removal and Installation section of this group for the procedures.

(2) From the underside of the cowl plenum cover/grille panel, disconnect the washer hose from the nozzle fitting.

(3) From the underside of the cowl plenum cover/grille panel, compress the retaining tabs of the washer nozzle and push the nozzle out through the top of the panel.

(4) Reverse the removal procedures to install.

REAR

(1) Using a trim stick or another suitable wide flat-bladed tool, pry gently at each side of the rear washer nozzle to release the snap clips that secure it to the liftgate outer panel.

(2) Pull the nozzle out from the liftgate outer panel far enough to access and disconnect the washer supply hose from the nozzle nipple.

(3) Reverse the removal procedures to install.

CHECK VALVE

A check valve is located in the washer supply hose near the top of the right liftgate opening pillar.

(1) Remove the right upper D-pillar trim. Refer to Group 23 - Body for the procedures.

(2) Disconnect the washer supply hoses from the barbed nipples on each end of the rear washer system check valve.

(3) Remove the check valve from the vehicle.

(4) When reinstalling the check valve, be certain the valve is properly oriented within the system flow (Fig. 22).

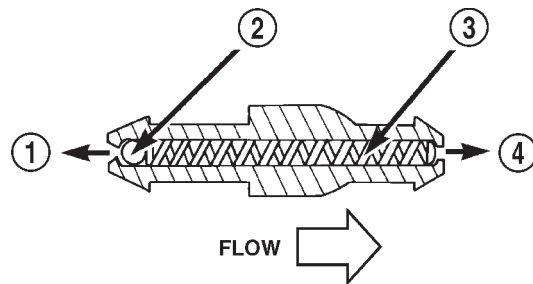

80abfece

Fig. 22 Rear Washer System Check Valve

- 1 - TO RESERVOIR
- 2 - CHECKBALL
- 3 - SPRING
- 4 - TO NOZZLE

(5) Reverse the remaining removal procedures to complete the installation.