

LAMPS

TABLE OF CONTENTS

| | page | | page |
|--------------------------|------|------------------------|------|
| SAFETY PRECAUTIONS | 1 | LAMP SERVICE | 15 |
| LAMP DIAGNOSIS | 2 | LAMP SYSTEMS | 21 |
| HEADLAMP ALIGNMENT | 6 | BULB APPLICATION | 22 |
| LAMP BULB SERVICE | 10 | | |

SAFETY PRECAUTIONS

TABLE OF CONTENTS

page

| | |
|---------------------------|---|
| SERVICE PROCEDURES | |
| SAFETY PRECAUTIONS | 1 |

SERVICE PROCEDURES

SAFETY PRECAUTIONS

WARNING: EYE PROTECTION SHOULD BE USED WHEN SERVICING GLASS COMPONENTS. PERSONAL INJURY CAN RESULT.

CAUTION: Do not touch the glass of halogen bulbs with fingers or other possibly oily surface, reduced bulb life will result.

Do not use bulbs with higher candle power than indicated in the Bulb Application table at the end of

this group. Damage to lamp and/or Daytime Running Lamp Module can result.

Do not use fuses, circuit breakers or relays having greater amperage value than indicated on the fuse panel or in the Owners Manual.

When it is necessary to remove components to service another, it should not be necessary to apply excessive force or bend a component to remove it. Before damaging a trim component, verify hidden fasteners or captured edges are not holding the component in place.

LAMP DIAGNOSIS

TABLE OF CONTENTS

page

DIAGNOSIS AND TESTING

SYSTEM DIAGNOSIS 2

DIAGNOSIS AND TESTING

when it comes in contact with the metal body, or through a separate ground wire.

SYSTEM DIAGNOSIS

A good ground is necessary for proper lighting operation. Grounding is provided by the lamp socket

Always begin any diagnosis by testing all of the fuses and circuit breakers in the system. Refer to Group 8W, Wiring Diagrams.

HEADLAMP

| CONDITION | POSSIBLE CAUSES | CORRECTION |
|---|---|--|
| HEADLAMPS ARE DIM WITH ENGINE IDLING OR IGNITION TURNED OFF | <ol style="list-style-type: none"> 1. Loose or corroded battery cables. 2. Loose or worn generator drive belt. 3. Charging system output too low. 4. Battery has insufficient charge. 5. Battery is sulfated or shorted. 6. Poor lighting circuit Z3-ground. 7. Both headlamp bulbs defective. | <ol style="list-style-type: none"> 1. Clean and secure battery cable clamps and posts. 2. Adjust or replace generator drive belt. 3. Test and repair charging system, refer to Group 8A, 4. Test battery state-of -charge , refer to Group 8A. 5. Load test battery, refer to Group 8A. 6. Test for voltage drop across Z3-ground locations, refer to Group 8W. 7. Replace both headlamp bulbs. |
| HEADLAMP BULBS BURN OUT FREQUENTLY | <ol style="list-style-type: none"> 1. Charging system output too high. 2. Loose or corroded terminals or splices in circuit. | <ol style="list-style-type: none"> 1. Test and repair charging system, refer to Group 8A. 2. Inspect and repair all connectors and splices, refer to Group 8W. |
| HEADLAMPS ARE DIM WITH ENGINE RUNNING ABOVE IDLE* | <ol style="list-style-type: none"> 1. Charging system output too low. 2. Poor lighting circuit Z3-ground. 3. High resistance in headlamp circuit. 4. Both headlamp bulbs defective. | <ol style="list-style-type: none"> 1. Test and repair charging system, refer to Group 8A. 2. Test for voltage drop across Z3-ground locations, refer to Group 8W. 3. Test amperage draw of headlamp circuit. 4. Replace both headlamp bulbs. |
| HEADLAMPS FLASH RANDOMLY | <ol style="list-style-type: none"> 1. Poor lighting circuit Z3-ground. 2. High resistance in headlamp circuit. 3. Loose or corroded terminals or splices in circuit. | <ol style="list-style-type: none"> 1. Test for voltage drop across Z3-ground locations, refer to Group 8W. 2. Test amperage draw of headlamp circuit. 3. Inspect and repair all connectors and splices, refer to Group 8W. |

DIAGNOSIS AND TESTING (Continued)

| CONDITION | POSSIBLE CAUSES | CORRECTION |
|---|---|---|
| HEADLAMPS (HIGH & LOW) DO NOT ILLUMINATE | <ol style="list-style-type: none"> 1. No voltage at either headlamp. 2. No ground for high and low beam circuit. 3. Headlamp bulb(s) defective. 4. Faulty headlamp switch. 5. Faulty headlamp dimmer (Multifunction) switch. 6. Broken connector terminal or wire splice in headlamp circuit. | <ol style="list-style-type: none"> 1. Voltage should always be present. Trace short circuit and replace BOTH headlamp fuses. Refer to Group 8W. Check wiring circuit from Right headlamp fuse to headlamp. (Repeat for Left side) 2. Ground should always be present according to switch position. Check ground at headlamp switch. Check wiring circuit from headlamp switch to Multifunction switch. Check headlamp switch and Multifunction switch continuity. Repair circuit ground, refer to Group 8W. 3. Replace bulb(s). 4. Replace headlamp switch. 5. Replace Multifunction switch. 6. Repair connector terminal or wire splice. |
| HEADLAMPS (LOW BEAM) DO NOT ILLUMINATE. | <ol style="list-style-type: none"> 1. No ground for low beam circuit. | <ol style="list-style-type: none"> 1. Ground should be present according to Multifunction switch position. Check wiring circuit from Multifunction switch to headlamp. Trace open circuit in wiring and repair. Refer to Group 8W. Check Multifunction Switch for continuity. |
| HEADLAMPS (HIGH BEAM) DO NOT ILLUMINATE. | <ol style="list-style-type: none"> 1. No ground for high beam circuit. | <ol style="list-style-type: none"> 1. Ground should be present according to Multifunction switch position. Check wiring circuit from Multifunction switch to headlamp. Trace open circuit in wiring and repair. Refer to Group 8W. Check Multifunction Switch for continuity. |
| HEADLAMPS (LOW BEAM) ALWAYS ILLUMINATE AND CAN NOT BE SHUT OFF. | <ol style="list-style-type: none"> 1. Low beam circuit from bulb to Multifunction switch is shorted to ground. | <ol style="list-style-type: none"> 1. Ground should be present according to Multifunction switch position. Check wiring circuit from Multifunction switch to headlamp. Trace short circuit in wiring and repair. Refer to Group 8W. |
| HEADLAMPS (HIGH BEAM) ALWAYS ILLUMINATE AND CAN NOT BE SHUT OFF. | <ol style="list-style-type: none"> 1. High beam circuit from bulb to Multifunction switch is shorted to ground. | <ol style="list-style-type: none"> 1. Ground should be present according to Multifunction switch position. Check wiring circuit from Multifunction switch to headlamp. Trace short circuit in wiring and repair. Refer to Group 8W. |
| HEADLAMP SWITCH OFF HEADLAMPS AND HIGHBEAM INDICATOR REMAIN ON AND ARE DIM. | <ol style="list-style-type: none"> 1. Headlamp switch feed circuit shorted to ground. | <ol style="list-style-type: none"> 1. Check wiring circuit from right headlamp fuse to headlamp. Repeat for left side. Trace short circuit in wiring and repair. Refer to Group W. |

DIAGNOSIS AND TESTING (Continued)

| CONDITION | POSSIBLE CAUSES | CORRECTION |
|---|--|---|
| HEADLAMP SWITCH ON (LOW BEAMS ON), ONE LOW BEAM ON AND BOTH HIGH BEAMS DIM. | 1. Headlamp feed circuit shorted to ground. | 1. Check wiring circuit from right headlamp fuse to headlamp. Repeat for left side. Trace short circuit in wiring and repair. Refer to Group W. |
| HEADLAMP SWITCH ON (HIGH BEAMS ON), ONE HIGH BEAM ON AND BOTH LOW BEAMS DIM. | 1. Headlamp feed circuit shorted to ground. | 1. Check wiring circuit from right headlamp fuse to headlamp. Repeat for left side. Trace short circuit in wiring and repair. Refer to Group W. |
| HEADLAMP SWITCH ON, ONE HEADLAMP FILAMENT WILL BE AT FULL INTENSITY AND ALL OTHER FILAMENTS ARE ON AND DIM. | 1. Blown headlamp fuse. 2. Open circuit from headlamp fuse to headlamp. | 1. Trace short circuit and replace fuse. Refer to Group 8W. 2. Repair open headlamp circuit, refer to Group 8W. |
| 1. HEADLAMPS STAY ON WITH KEY OUT (DRLM EQUIPPED VEHICLES). | 1. Failed DRLM | 1. Replace DRLM. |
| *Canada vehicles must have lamps ON. | | |

FOG LAMP

| CONDITION | POSSIBLE CAUSES | CORRECTION |
|--|--|--|
| FOG LAMPS ARE DIM WITH ENGINE IDLING OR IGNITION TURNED OFF. | 1. Loose or corroded battery cables. 2. Loose or worn generator drive belt. 3. Charging system output too low. 4. Battery has insufficient charge. 5. Battery is sulfated or shorted. 6. Poor lighting circuit Z3-ground. | 1. Clean and secure battery cable clamps and posts. 2. Adjust or replace generator drive belt. 3. Test and repair charging system. Refer to Group 8A, 4. Test battery state-of -charge. Refer to Group 8A. 5. Load test battery. Refer to Group 8A. 6. Test for voltage drop across Z3-ground locations. Refer to Group 8W. |
| FOG LAMP BULBS BURN OUT FREQUENTLY | 1. Charging system output too high. 2. Loose or corroded terminals or splices in circuit. | 1. Test and repair charging system. Refer to Group 8A. 2. Inspect and repair all connectors and splices. Refer to Group 8W. |
| FOG LAMPS ARE DIM WITH ENGINE RUNNING ABOVE IDLE | 1. Charging system output too low. 2. Poor lighting circuit Z3-ground. 3. High resistance in fog lamp circuit. | 1. Test and repair charging system. Refer to Group 8A. 2. Test for voltage drop across Z3-ground locations. Refer to Group 8W. 3. Test amperage draw of fog lamp circuit. |

DIAGNOSIS AND TESTING (Continued)

| CONDITION | POSSIBLE CAUSES | CORRECTION |
|---|--|--|
| FOG LAMPS FLASH RANDOMLY | <ol style="list-style-type: none"> 1. Poor lighting circuit Z3-ground. 2. High resistance in fog lamp circuit. 3. Faulty fog lamp switch. 4. Loose or corroded terminals or splices in circuit. | <ol style="list-style-type: none"> 1. Test for voltage drop across Z3-ground locations. Refer to Group 8W. 2. Test amperage draw of fog lamp circuit. 3. Replace fog lamp switch. 4. Inspect and repair all connectors and splices. Refer to Group 8W. |
| FOG LAMPS DO NOT ILLUMINATE | <ol style="list-style-type: none"> 1. Blown fuse for fog lamp. 2. No Z3-ground at fog lamps. 3. Faulty fog lamp switch. 4. Broken connector terminal or wire splice in fog lamp circuit. 5. Defective or burned out bulb. | <ol style="list-style-type: none"> 1. Trace short and replace fuse. Refer to Group 8W. 2. Repair circuit ground. Refer to Group 8W. 3. Replace fog lamp switch. 4. Repair connector terminal or wire splice. 5. Replace bulb. |
| FOG LAMPS ARE INOPERATIVE AND FOG LAMP INDICATOR LIGHT ALWAYS STAYS ON. | <ol style="list-style-type: none"> 1. Fog lamp/DRL* feed shorted to ground. | <ol style="list-style-type: none"> 1. Check wiring circuit from fog lamp/DRL* fuse to fog lamp. Trace short circuit in wiring and repair. Refer to Group 8W. |
| FOG LAMPS ARE INOPERATIVE AND FOG LAMP INDICATOR LIGHT IS ILLUMINATED. | <ol style="list-style-type: none"> 1. Fog lamp/DRL* fuse defective. 2. Open circuit from fog lamp fuse to fog lamp. | <ol style="list-style-type: none"> 1. Trace short circuit and replace fuse. Refer to Group 8W. 2. Check wiring circuit from fog lamp/DRL* fuse to fog lamp. Trace open circuit in wiring and repair. Refer to Group 8W. |
| PARK LAMPS ARE INOPERATIVE. FOG LAMP INDICATOR IS ON WHEN ALL SWITCHES ARE OFF AND FUNCTIONS OPPOSITE TO FOG LAMPS. | <ol style="list-style-type: none"> 1. Park lamp feed is shorted. | <ol style="list-style-type: none"> 1. Check wiring circuit from park lamp fuse to headlamp switch. Trace short circuit in wiring and repair. Refer to Group 8W. |
| PARK LAMPS ARE INOPERATIVE. FOG LAMP INDICATOR FUNCTIONS OPPOSITE TO FOG LAMPS. | <ol style="list-style-type: none"> 1. Park lamp fuse is defective. 2. Open circuit from park lamp fuse to headlamp switch. | <ol style="list-style-type: none"> 1. Trace short circuit and replace fuse. Refer to Group 8W. 2. Check wiring circuit from park lamp fuse to headlamp switch. Trace open circuit in wiring and repair. Refer to Group 8W. |
| <p>*Canada vehicles use Daytime Running Lamps (DRL).</p> | | |

HEADLAMP ALIGNMENT

TABLE OF CONTENTS

| | page | page | |
|--|------|-------------------------|---|
| SERVICE PROCEDURES | | | |
| HEADLAMP ALIGNMENT..... | 6 | HEADLAMP ALIGNMENT..... | 7 |
| LAMP ALIGNMENT SCREEN PREPARATION..... | 6 | FOG LAMP ALIGNMENT..... | 8 |
| VEHICLE PREPARATION FOR HEADLAMP ALIGNMENT..... | 6 | SPECIAL TOOLS | |
| | | HEADLAMP ALIGNMENT..... | 9 |

SERVICE PROCEDURES

HEADLAMP ALIGNMENT

Headlamps can be aligned using the screen method provided in this section. Alignment Tool C-4466-A or equivalent can also be used. Refer to instructions provided with the tool for proper procedures.

LAMP ALIGNMENT SCREEN PREPARATION

(1) Position vehicle on a level surface perpendicular to a flat wall 7.62 meters (25 ft) away from front of headlamp lens (Fig. 1).

(2) If necessary, tape a line on the floor 7.62 meters (25 ft) away from and parallel to the wall.

(3) Up 1.27 meters (5 feet) from the floor, tape a line on the wall at the centerline of the vehicle. Sight along the centerline of the vehicle (from rear of vehicle forward) to verify accuracy of the line placement.

(4) Rock vehicle side-to-side three times to allow suspension to stabilize.

(5) Jounce front suspension three times by pushing downward on front bumper and releasing.

(6) Measure the distance from the center of headlamp lens to the floor. Transfer measurement to the alignment screen (with tape). Use this line for up/down adjustment reference.

(7) Measure distance from the centerline of the vehicle to the center of each headlamp being aligned. Transfer measurements to screen (with tape) to each side of vehicle centerline. Use these lines for left/right adjustment reference.

VEHICLE PREPARATION FOR HEADLAMP ALIGNMENT

(1) Verify headlamp dimmer switch and high beam indicator operation.

(2) Correct defective components that could hinder proper headlamp alignment.

(3) Verify proper tire inflation.

(4) Clean headlamp lenses.

(5) Verify that luggage area is not heavily loaded.

(6) Fuel tank should be FULL. Add 2.94 kg (6.5 lbs.) of weight over the fuel tank for each estimated gallon of missing fuel.

SERVICE PROCEDURES (Continued)

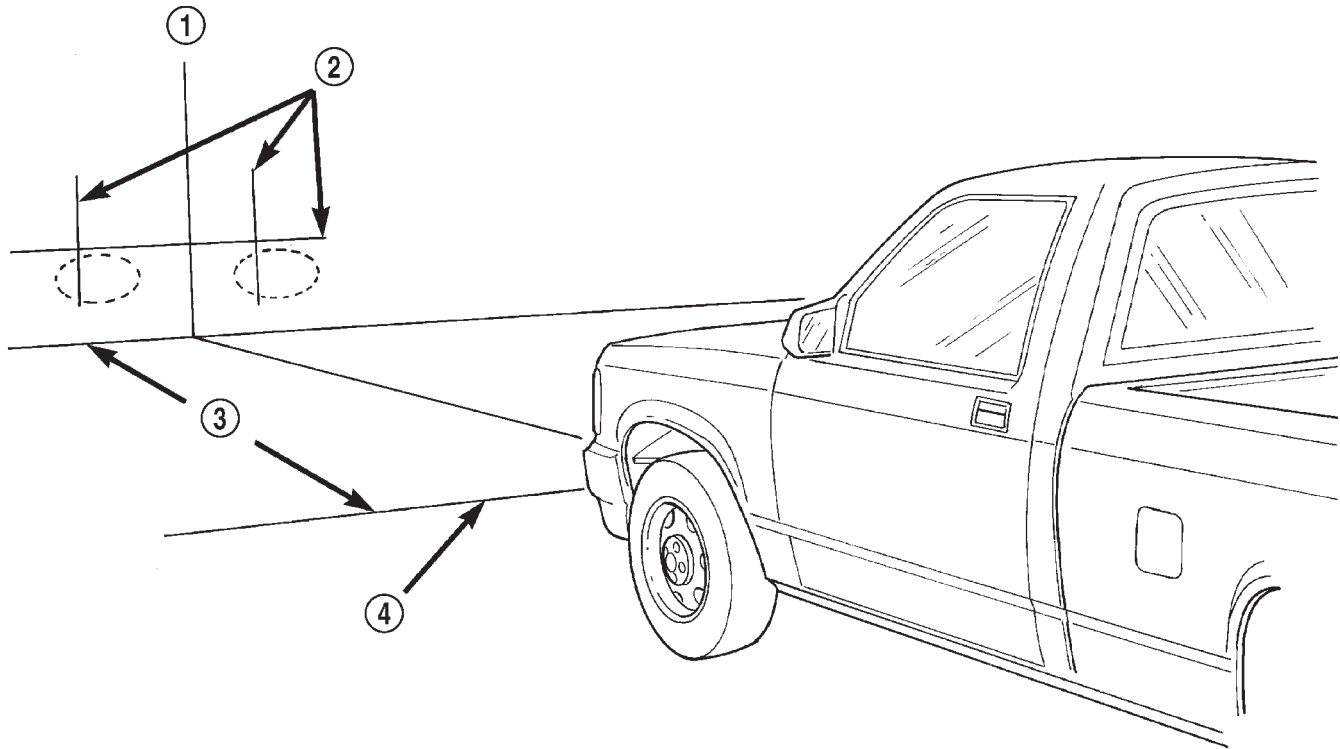

8020cdbf

Fig. 1 Headlamp Alignment Screen—Typical

- 1 - CENTER OF VEHICLE
- 2 - CENTER OF HEADLAMP

- 3 - 7.62 METERS (25 FT.)
- 4 - FRONT OF HEADLAMP

HEADLAMP ALIGNMENT

A properly aimed low beam headlamp will project top edge of high intensity pattern on screen from 50 mm (2 in.) above to 50 mm (2 in.) below headlamp centerline. The side-to-side outboard edge of high intensity pattern should be from 50 mm (2 in.) left to 50 mm (2 in.) right of headlamp centerline (Fig. 1). **The preferred headlamp alignment is 1" down for the up/down adjustment and 0 for the left/right adjustment.** The high beam pattern should be correct when the low beams are aligned properly.

To adjust low beam headlamp, rotate alignment screws (Fig. 2) to achieve the specified aim.

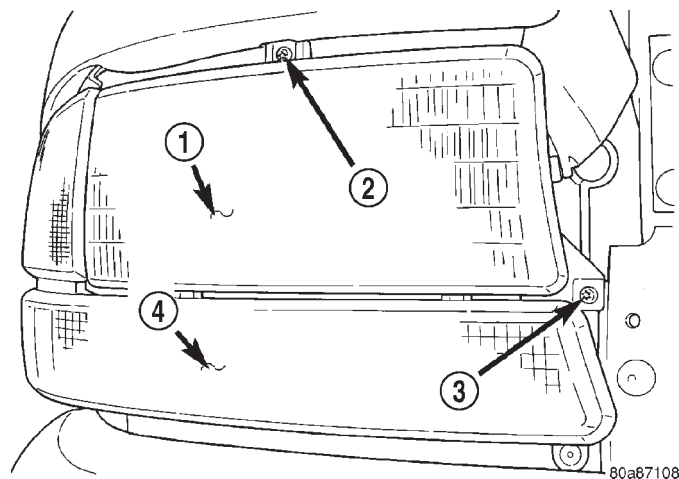

80a87108

Fig. 2 Headlamp Adjustment Screws

- 1 - HEADLAMP
- 2 - UP/DOWN ADJUSTMENT
- 3 - LEFT/RIGHT ADJUSTMENT
- 4 - PARK LAMP

SERVICE PROCEDURES (Continued)

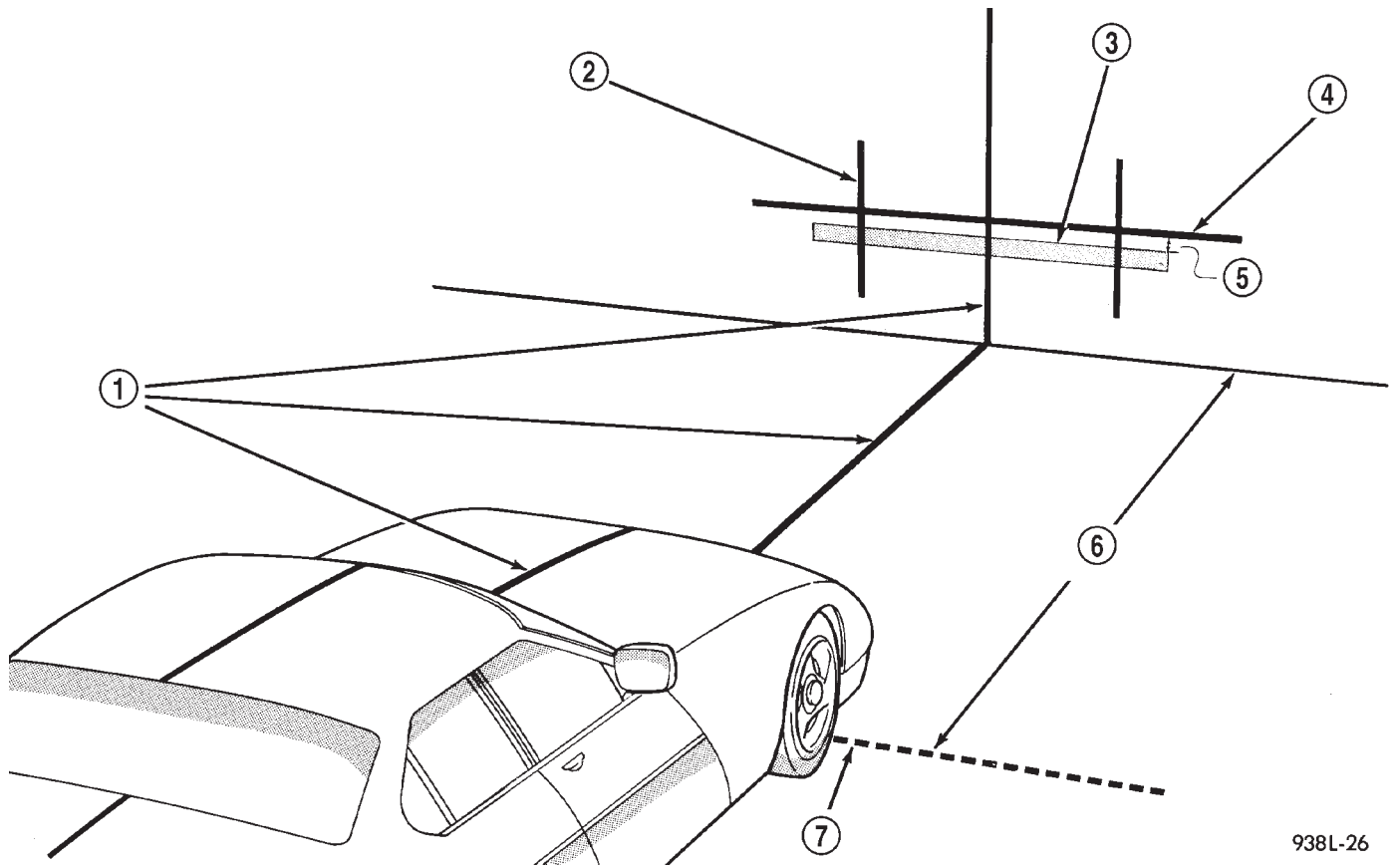

938L-26

Fig. 3 Fog Lamp Alignment —Typical

- 1 - VEHICLE CENTERLINE
- 2 - CENTER OF VEHICLE TO CENTER OF FOG LAMP LENS
- 3 - HIGH-INTENSITY AREA
- 4 - FLOOR TO CENTER OF FOG LAMP LENS
- 5 - 100 mm (4 in.)
- 6 - 7.62 METERS (25 FEET)
- 7 - FRONT OF FOG LAMP

FOG LAMP ALIGNMENT

Prepare an alignment screen. Refer to Alignment Screen Preparation paragraph in this section. A properly aligned fog lamp will project a pattern on the alignment screen 100 mm (4 in.) below the fog lamp centerline and straight ahead (Fig. 3). Rotate the adjustment screw to adjust beam height (Fig. 4).

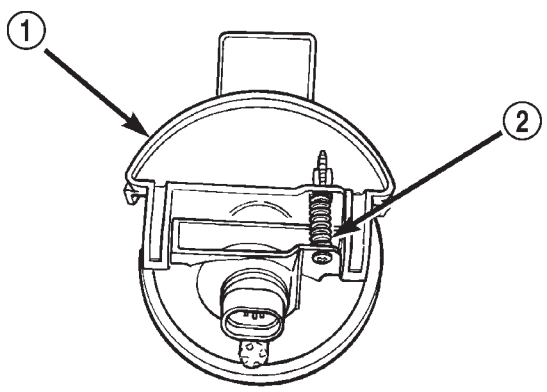

80a8eb48

Fig. 4 Fog Lamp Adjustment

- 1 - FOG LAMP
- 2 - ADJUSTMENT SCREW

SPECIAL TOOLS

HEADLAMP ALIGNMENT

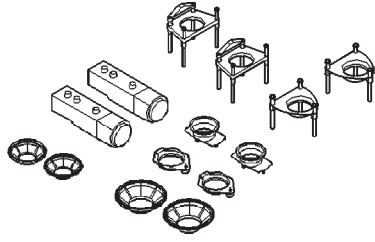

Headlamp Aiming Kit C-4466-A

LAMP BULB SERVICE

TABLE OF CONTENTS

| | page | | page |
|---------------------------------------|------|---------------------------------------|------|
| REMOVAL AND INSTALLATION | | | |
| HEADLAMP BULB | 10 | TAIL, BRAKE, TURN SIGNAL AND BACK-UP | |
| FOG LAMP BULB | 10 | LAMP BULB | 11 |
| PARK AND TURN SIGNAL LAMP BULBS | 11 | LICENSE PLATE LAMP BULB | 12 |
| FRONT SIDE MARKER LAMP BULB | 11 | UNDERHOOD LAMP BULB | 12 |
| CENTER HIGH MOUNTED STOP LAMP | | DOME LAMP BULB | 13 |
| (CHMSL) BULB | 11 | 2ND SEAT DOME/READING LAMP BULB | 13 |
| LIFTGATE/CARGO LAMP BULB | 11 | OVERHEAD CONSOLE READING LAMP BULB .. | 14 |

REMOVAL AND INSTALLATION

HEADLAMP BULB

REMOVAL

- (1) Open hood.
- (2) Remove headlamp assembly. See headlamp removal in the lamp service section.
- (3) Remove the retaining ring holding bulb to headlamp.
- (4) Pull bulb socket from headlamp (Fig. 1).
- (5) Grasp bulb and pull from socket.

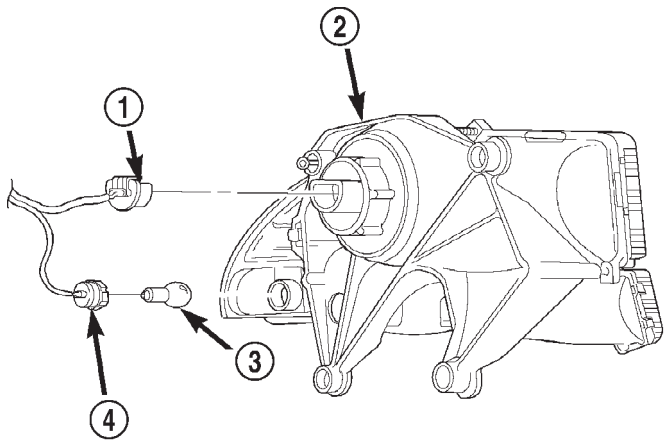

80a61c8f

Fig. 1 Headlamp Bulb

- 1 - HEADLAMP BULB SOCKET
- 2 - HEADLAMP
- 3 - BULB
- 4 - SIDE MARKER LAMP BULB SOCKET

INSTALLATION

CAUTION: Do not touch the bulb glass with fingers or other oily surfaces. Reduced bulb life will result.

- (1) Position bulb into socket and push into place.
- (2) Position bulb socket in headlamp.
- (3) Install retaining ring holding bulb to headlamp.
- (4) Install headlamp assembly.

FOG LAMP BULB

REMOVAL

- (1) Disengage fog lamp harness connector.
- (2) Rotate bulb socket a 1/4 turn counterclockwise and pull from lamp to separate (Fig. 2).
- (3) Grasp bulb and pull from lamp.

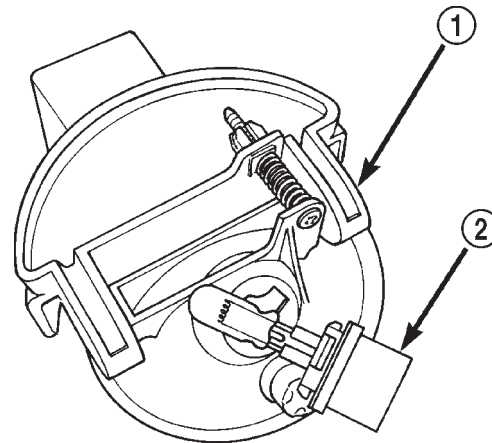

80a8eb55

Fig. 2 Fog Lamp Bulb

- 1 - FOG LAMP
- 2 - FOG LAMP BULB

INSTALLATION

CAUTION: Do not touch the bulb glass with fingers or other oily surfaces. Reduced bulb life will result.

- (1) Position bulb in lamp, push to seat and rotate a 1/4 turn clockwise.
- (2) Connect fog lamp harness connector.

REMOVAL AND INSTALLATION (Continued)

PARK AND TURN SIGNAL LAMP BULBS

REMOVAL

- (1) Remove park and turn signal lamp.
- (2) Rotate bulb socket 1/4 turn counterclockwise and pull turn signal lamp socket from back of lamp (Fig. 3).
- (3) Pull park and turn signal lamp bulb from socket.

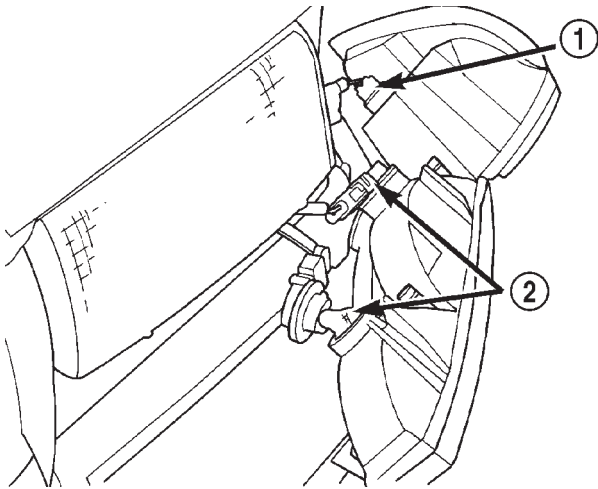

80a82cf6

Fig. 3 Park And Turn Signal Lamp bulb

- 1 - SIDE MARKER LAMP BULB
- 2 - PARK/TURN SIGNAL LAMP BULB

INSTALLATION

- (1) Install park and turn signal lamp bulb in socket.
- (2) Install park and turn signal lamp socket into back of lamp.
- (3) Install park/turn signal lamp.

FRONT SIDE MARKER LAMP BULB

REMOVAL

- (1) Remove park and turn signal lamp.
- (2) Remove side marker lamp socket from back of lamp (Fig. 1).
- (3) Pull side marker lamp bulb from socket.

INSTALLATION

- (1) Install side marker lamp bulb in socket.
- (2) Install side marker lamp socket into back of lamp.
- (3) Install park/turn signal lamp.

CENTER HIGH MOUNTED STOP LAMP (CHMSL) BULB

REMOVAL

- (1) Remove CHMSL from liftgate.
- (2) Turn bulb socket 1/4 turn counterclockwise.
- (3) Separate socket from lamp.
- (4) Grasp bulb and pull from socket.

INSTALLATION

- (1) Position bulb in socket and press into place.
- (2) Position socket in lamp.
- (3) Turn bulb socket 1/4 turn clockwise.
- (4) Install CHMSL.

LIFTGATE/CARGO LAMP BULB

REMOVAL

- (1) Remove liftgate/cargo lamp from liftgate.
- (2) Using a small flatblade, pry lamp lens from lamp.
- (3) Remove bulb from lamp.

INSTALLATION

- (1) Install in bulb in lamp.
- (2) Install lamp lens on lamp.
- (3) Install liftgate/cargo lamp in liftgate.

TAIL, BRAKE, TURN SIGNAL AND BACK-UP LAMP BULB

REMOVAL

- (1) Release liftgate latch and open liftgate.
- (2) Remove screws attaching tail, brake, turn signal and back-up lamp to liftgate opening.
- (3) Separate inner end of lamp from quarter panel.
- (4) Disengage hook holding outer end of lamp to quarter panel opening.
- (5) Separate lamp from quarter panel.
- (6) Rotate lamp socket counterclockwise one quarter turn (Fig. 4).
- (7) Pull socket from back of lamp.
- (8) Pull bulb from socket (Fig. 5).

INSTALLATION

- (1) Align key on bulb base to groove in socket and insert bulb into socket (Fig. 5).
- (2) Insert socket into back of lamp.
- (3) Rotate lamp socket clockwise one quarter turn.
- (4) Engage hook to hold outer end of lamp to quarter panel opening.
- (5) Place lamp in position on quarter panel.
- (6) Install screws attaching lamp to liftgate opening.

REMOVAL AND INSTALLATION (Continued)

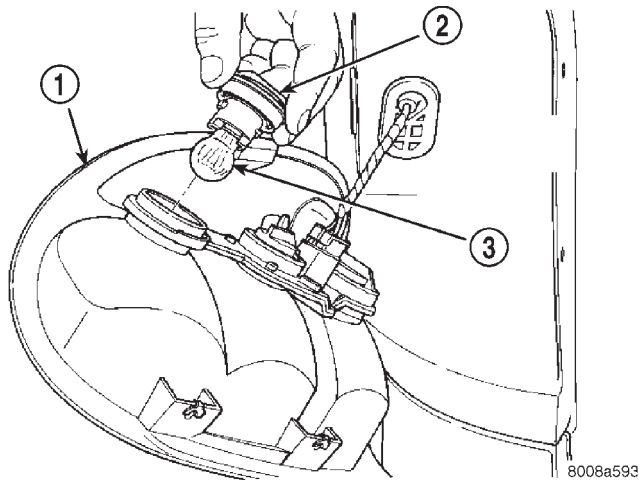

Fig. 4 Tail, Brake, Turn Signal and Back-up Lamp Bulb

- 1 - TAIL, STOP AND TURN SIGNAL LAMP
- 2 - SOCKET
- 3 - BULB

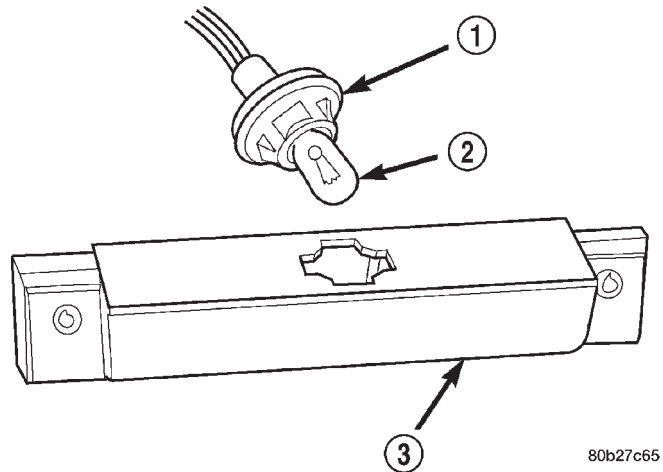

Fig. 6 License Plate Lamp Bulb

- 1 - SOCKET
- 2 - BULB
- 3 - LICENSE PLATE LAMP

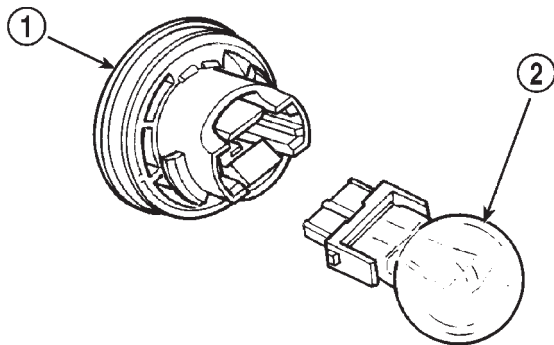

Fig. 5 Pull Bulb From Socket

- 1 - SOCKET
- 2 - BULB

LICENSE PLATE LAMP BULB

REMOVAL

- (1) Remove license plate lamp from rear bumper.
- (2) Remove bulb socket from lamp (Fig. 6).
- (3) Pull bulb from socket.

INSTALLATION

- (1) Push bulb in socket.
- (2) Install bulb socket in lamp.
- (3) Install license plate lamp in rear bumper.

UNDERHOOD LAMP BULB

REMOVAL

- (1) Insert a small flat blade in the access slot between the lamp base and lamp lens.
- (2) Pry the lamp lens upward and remove the lamp lens (Fig. 7).
- (3) Depress the bulb terminal inward (Fig. 8) to release the bulb.

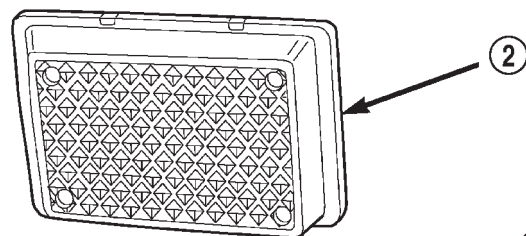
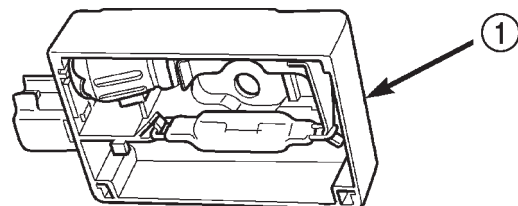

Fig. 7 Underhood Lamp Lens

- 1 - LAMP
- 2 - LAMP LENS

REMOVAL AND INSTALLATION (Continued)

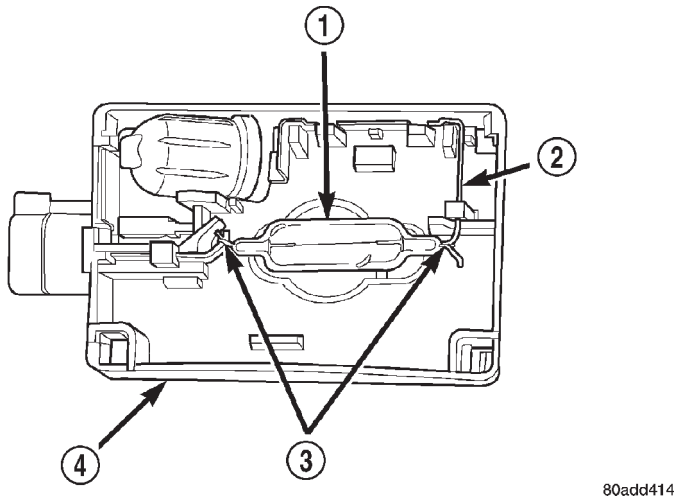

Fig. 8 Underhood Lamp Bulb

- 1 - BULB
- 2 - DEPRESS TERMINAL INWARD
- 3 - BULB WIRE LOOP
- 4 - LAMP BASE

INSTALLATION

- (1) Engage the replacement bulb wire loop to the terminal closest to the lamp base wire connector.
- (2) Depress the opposite terminal inward and engage the remaining bulb wire loop.
- (3) Position the lamp lens on the lamp base and press into place.

DOME LAMP BULB

REMOVAL

- (1) Using a small flat blade, pry the left side (driver's side) of the lamp lens downward.
- (2) Pull bulb from lamp.

INSTALLATION

- (1) Install bulb in lamp.
- (2) Position lens on lamp and snap into place.

2ND SEAT DOME/READING LAMP BULB

REMOVAL

- (1) Using a small flat blade, pry the center rearward edge of the dome/reading lamp lens downward from lamp (Fig. 9).
- (2) Pull bulb from socket (Fig. 10).

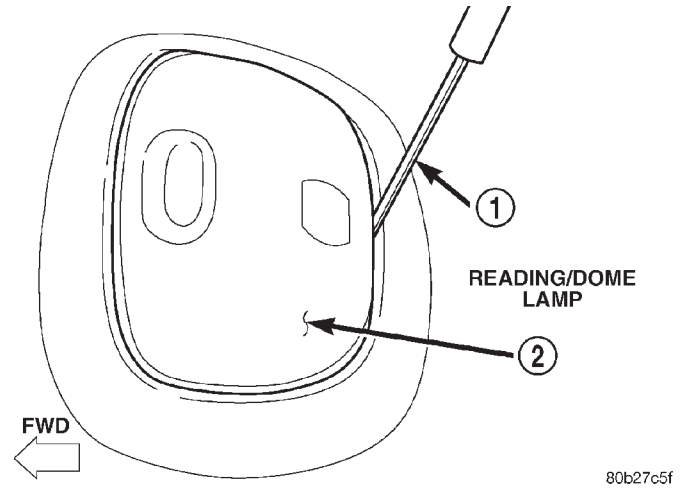

Fig. 9 Lamp Lens

- 1 - FLAT BLADE
- 2 - LENS

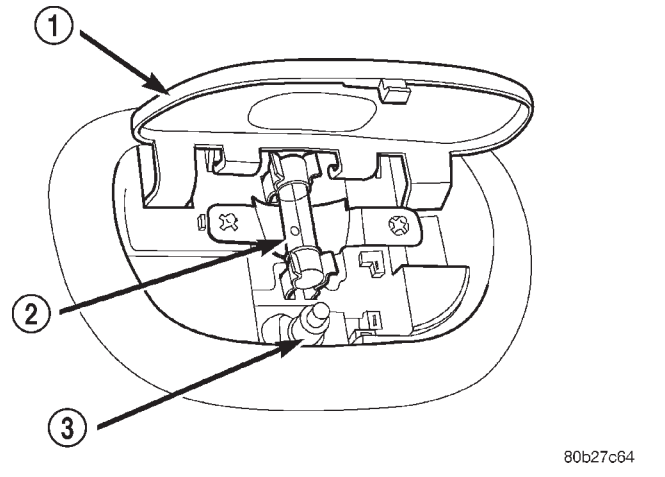

Fig. 10 Dome/Reading Lamp Bulb

- 1 - LAMP LENS
- 2 - BULB
- 3 - SWITCH

INSTALLATION

- (1) Position bulb in lamp.
- (2) Push the lamp lens up into the lamp to secure.

REMOVAL AND INSTALLATION (Continued)

OVERHEAD CONSOLE READING LAMP BULB**REMOVAL**

- (1) Using a small flat blade, carefully pry forward edge of reading lamp lens downward from lamp.
- (2) Disengage lamp lens from pivots on overhead console.
- (3) Rotate bulb holder and pull bulb from lamp.

INSTALLATION

- (1) Position bulb in lamp and rotate to secure.
- (2) Position lamp lens on overhead console. Ensure contact tab (Fig. 11) on lamp lens is aligned with lamp switch.
- (3) Carefully press lamp lens onto pivots.

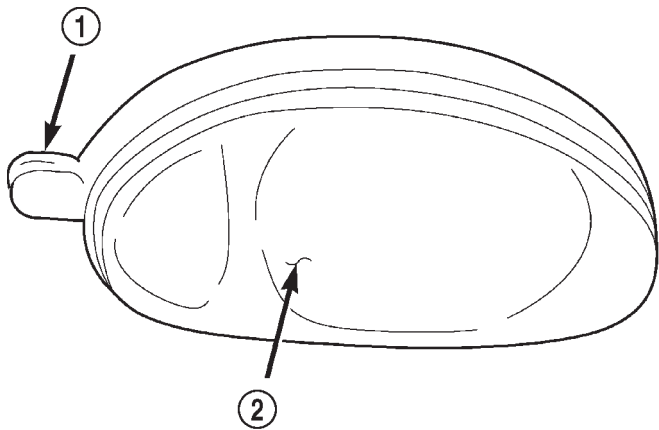

80b27c66

Fig. 11 Reading Lamp Lens

- 1 - SWITCH CONTACT TAB
2 - READING LAMP LENS
-

LAMP SERVICE TABLE OF CONTENTS

| | page | | page |
|---|------|--|------|
| DESCRIPTION AND OPERATION | | LIFTGATE/CARGO LAMP | 17 |
| LAMP SYSTEMS | 15 | TAIL, BRAKE, TURN SIGNAL AND BACK-UP LAMP | 17 |
| REMOVAL AND INSTALLATION | | LICENSE PLATE LAMP | 18 |
| HEADLAMP | 16 | UNDERHOOD LAMP | 18 |
| FOG LAMP | 16 | DOMELAMP | 19 |
| PARK, TURN SIGNAL AND SIDE MARKER LAMP | 16 | 2ND SEAT DOME/READING LAMP | 19 |
| CENTER HIGH MOUNTED STOP LAMP (CHMSL) | 17 | OVERHEAD CONSOLE READING LAMP | 20 |

DESCRIPTION AND OPERATION

LAMP SYSTEMS

Each vehicle is equipped with various lamp assemblies. A good ground is necessary for proper lighting operation. Grounding is provided through a separate ground wire.

When changing lamp bulbs check the socket for corrosion. If corrosion is present, clean it with a wire brush and coat the inside of the socket lightly with Mopar® Multi-Purpose Grease or equivalent.

HEADLAMPS

DESCRIPTION

Headlamps on the Durango are modular in design. The turn/park lamp module is incorporated into the headlamp module. The module contains four bulbs; a dual filament headlamp bulb, two dual filament turn/park bulbs, and a side marker bulb.

OPERATION

Headlamps and parking lamps are controlled by the headlamp switch. The multifunction switch mounted on the steering column controls the high beam function, and the turn signal function.

HEADLAMP SWITCH

DESCRIPTION

The headlamp switch modules located on the instrument panel. The headlamp switch controls the parking lamps and the headlamps. A separate switch in the module controls the interior lamps, and instrument cluster illumination. This switch also contains a rheostat for controlling the illumination level of the instrument cluster lamps.

OPERATION

The headlamp switch has an off position, a parking lamp position, and a headlamp on position. High

beams are controlled by the multifunction switch on the steering column. The headlamp switch cannot be repaired. It must be replaced. Refer to Group 8E for removal and installation procedures, and Group 8W for wiring.

DAYTIME RUNNING LAMP MODULE

DESCRIPTION

The Daytime Running Lights (Headlamps) System is installed on vehicles manufactured for sale in Canada only. A separate module, mounted on the cowl, controls the DRL.

OPERATION

The headlamps are illuminated when the ignition switch is turned to the ON position. The DRL module receives a vehicle-moving signal from the vehicle speed sensor. This provides a constant **headlamps-on** condition as long as the vehicle is moving. The lamps are illuminated at less than 50 percent of normal intensity.

TAIL/STOP/TURN SIGNAL/BACK-UP LAMP

DESCRIPTION

The taillamps on the Durango are mounted at the rear of the vehicle, outboard of the rear hatch and integrated into the lines of the vehicle. The taillamp module contains a housing, lens, and three bulbs. Dual filament bulb is used for tail, stop, and turn signal operations. A separate bulb is used for back-up illumination.

OPERATION

Tail lamp functions are controlled by the headlamp switch. Turn signal operations are controlled by the multifunction switch. Stop lamp functions are controlled by the stoplamp switch. The back-up lamps are controlled by the back-up lamp switch on the transmission.

REMOVAL AND INSTALLATION

HEADLAMP

REMOVAL

- (1) Open hood.
- (2) Remove the bolts attaching headlamp to the inner fender panel (Fig. 1).
- (3) Grasp the headlamp and firmly pull the headlamp to disengage it from the panel.
- (4) Disengage the connector from the headlamp bulb.
- (5) Separate bulb from headlamp.
- (6) Remove the bulb sockets from the front park/turn signal/side marker lamps
- (7) Separate headlamp module from vehicle.

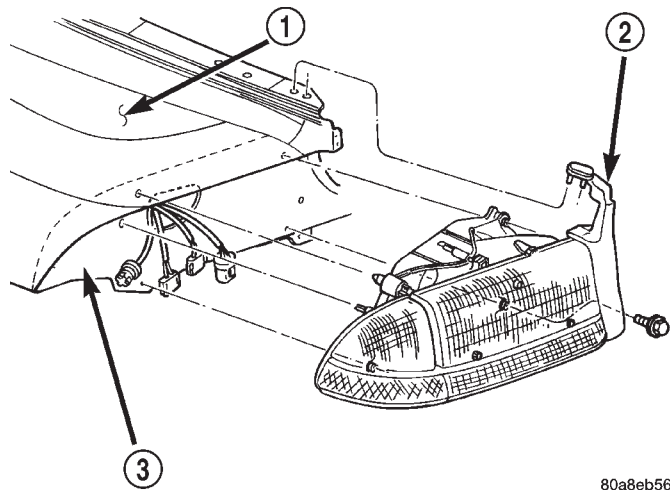

Fig. 1 Headlamp

- 1 - FENDER
2 - SEAL
3 - INNER FENDER

INSTALLATION

CAUTION: Do not touch the bulb glass with fingers or other oily surfaces. Reduced bulb life will result.

- (1) Install bulb sockets for the front park/turn signal/side marker lamps
- (2) Engage the connector to the headlamp bulb.
- (3) Position headlamp in inner fender panel and firmly push headlamp inward to lock into place.
- (4) Install the bolts attaching headlamp to the panel.

FOG LAMP

The fog lamps are serviced from the rearward side of the front bumper.

REMOVAL

- (1) Disengage fog lamp harness connector.

- (2) Remove the bolts attaching the fog lamp to the bumper (Fig. 2).
- (3) Separate fog lamp from bumper.

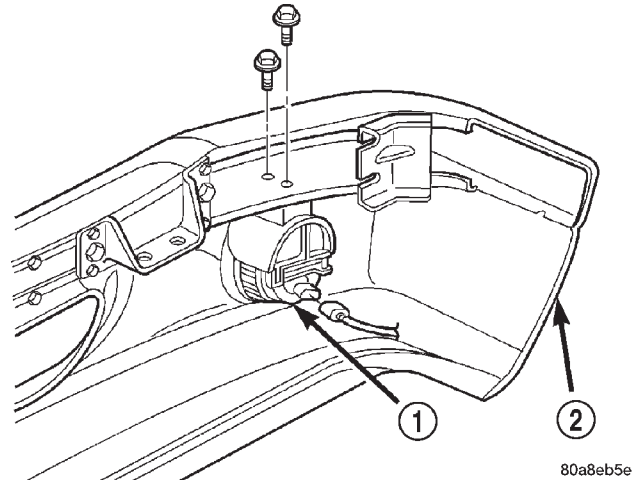

Fig. 2 Fog Lamp

- 1 - FOG LAMP
2 - FRONT BUMPER

INSTALLATION

- (1) Position fog lamp in bumper.
- (2) Install the bolts attaching the fog lamp to the bumper.
- (3) Connect fog lamp harness connector.
- (4) Check for proper operation and beam alignment.

PARK, TURN SIGNAL AND SIDE MARKER LAMP

REMOVAL

- (1) Remove torx screw attaching park lamp to headlamp module (Fig. 3).
- (2) Pull the park and turn signal lamp outward and separate from headlamp module.
- (3) Remove park and turn signal sockets from back of lamp (Fig. 4).
- (4) Remove side marker socket from back of lamp.
- (5) Separate park and turn signal lamp from vehicle.

INSTALLATION

- (1) Install side marker socket in back of lamp.
- (2) Install park and turn signal sockets in back of lamp.
- (3) Using the guides on the bottom and side of the headlamp module, align the park and turn signal lamp under headlamp module.
- (4) Slide the park and turn signal lamp inward under headlamp module. Push firmly until the lamp is seated.

REMOVAL AND INSTALLATION (Continued)

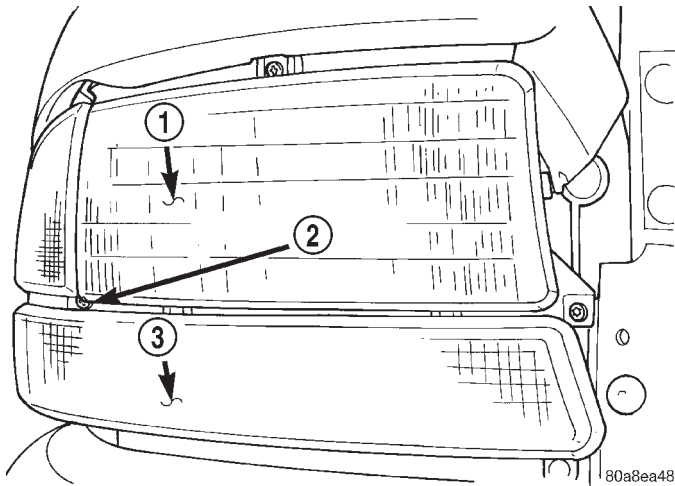

Fig. 3 Park Lamp Screw

- 1 - HEADLAMP
- 2 - HIDDEN SCREW
- 3 - PARK LAMP

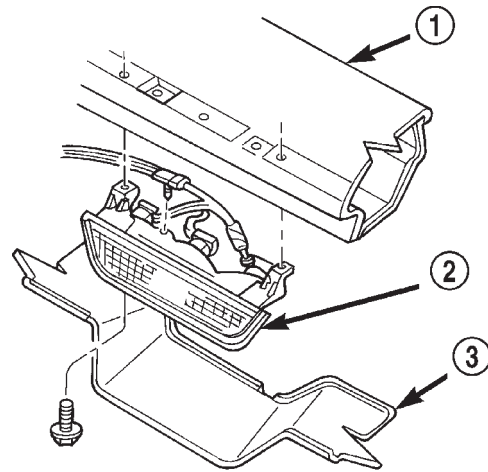

Fig. 5 Center High Mounted Stop Lamp

- 1 - LIFTGATE
- 2 - CHMSL
- 3 - LIFTGATE TRIM

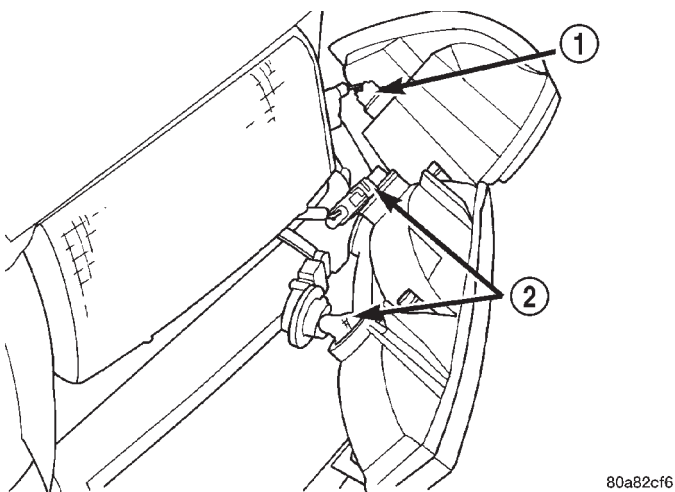

Fig. 4 Park, Turn Signal And Side Marker Lamp

- 1 - SIDE MARKER LAMP BULB
- 2 - PARK/TURN SIGNAL LAMP BULB

(5) Install screw attaching park lamp to headlamp module.

CENTER HIGH MOUNTED STOP LAMP (CHMSL)

REMOVAL

- (1) Remove liftgate trim panel.
- (2) Remove CHMSL lamp mounting screws (Fig. 5).
- (3) Remove CHMSL lamp.
- (4) Turn bulb sockets 1/4 turn counterclockwise.
- (5) Separate socket from lamp.

INSTALLATION

- (1) Position socket in lamp.
- (2) Turn bulb sockets 1/4 turn clockwise.
- (3) Position CHMSL lamp in place and install mounting screws.
- (4) Install liftgate trim panel.

LIFTGATE/CARGO LAMP

REMOVAL

- (1) Using a small flatblade, carefully pry the outward edge of the liftgate/cargo lamp from trim panel.
- (2) Release the locking tab on the lamp harness connector and disconnect the harness connector from the lamp.
- (3) Separate the lamp from the liftgate (Fig. 6).

INSTALLATION

- (1) Connect the harness connector to the lamp.
- (2) Position the lamp in the liftgate and press inward to secure.

TAIL, BRAKE, TURN SIGNAL AND BACK-UP LAMP

REMOVAL

- (1) Release liftgate latch and open liftgate.
- (2) Remove screws attaching tail, brake, turn signal and back-up lamp to liftgate opening (Fig. 7).
- (3) Separate inner end of lamp from quarter panel.
- (4) Disengage hook holding outer end of lamp to quarter panel opening.
- (5) Separate lamp from quarter panel.
- (6) Disengage positive lock on wire connector (Fig. 8).

REMOVAL AND INSTALLATION (Continued)

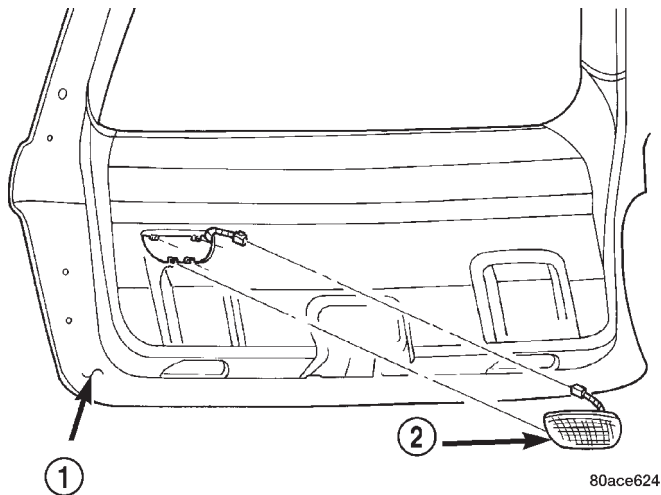
**Fig. 6 Liftgate/Cargo Lamp**

- 1 - LIFTGATE
- 2 - LIFTGATE LAMP

(7) Depress lock tab on the side of the body harness connector.

(8) Disengage wire connector from tail lamp circuit board.

(9) Separate tail lamp from vehicle.

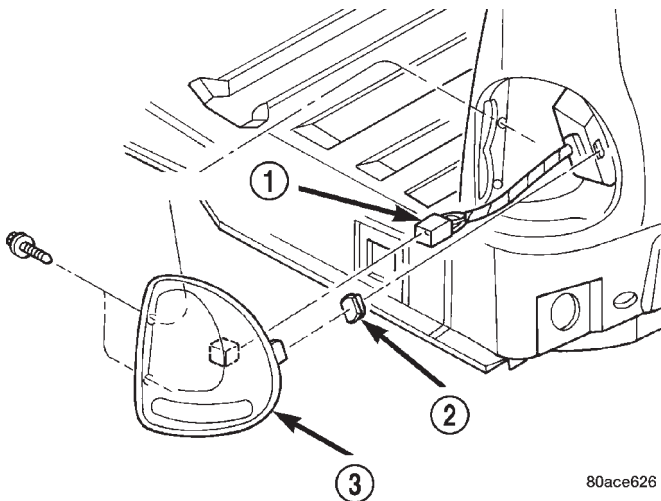
**Fig. 7 Tail, Brake, Turn Signal and Back-up Lamp**

- 1 - CONNECTOR
- 2 - GROMMET
- 3 - TAIL LAMP

INSTALLATION

- (1) Place tail lamp in position on vehicle.
- (2) Engage wire connector into tail lamp circuit board.
- (3) Engage positive lock on wire connector.
- (4) Place lamp in position in position on quarter panel.
- (5) Engage hook to hold outer end of lamp to quarter panel opening.

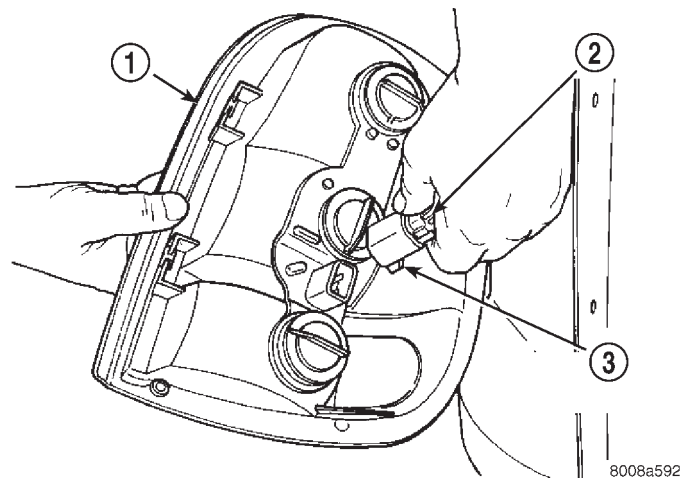
**Fig. 8 Tail Lamp Connector**

- 1 - TAIL, STOP AND TURN SIGNAL LAMP
- 2 - WIRE CONNECTOR
- 3 - POSITIVE LOCK

- (6) Position inner end of lamp into quarter panel.
- (7) Install screws attaching tail, stop, turn signal and back-up lamp to liftgate opening.

LICENSE PLATE LAMP**REMOVAL**

- (1) Remove screws attaching license plate lamp to rear bumper.
- (2) Remove bulb socket from lamp.
- (3) Separate lamp from bumper.

INSTALLATION

- (1) Install bulb socket in lamp.
- (2) Position lamp at bumper.
- (3) Install screws attaching license plate lamp to rear bumper.

UNDERHOOD LAMP**REMOVAL**

- (1) Disconnect the wire harness connector from the lamp.
- (2) Remove lamp lens.
- (3) Remove bulb.
- (4) Remove screw attaching underhood lamp to the inner hood panel (Fig. 9).
- (5) Separate underhood lamp from vehicle.

REMOVAL AND INSTALLATION (Continued)

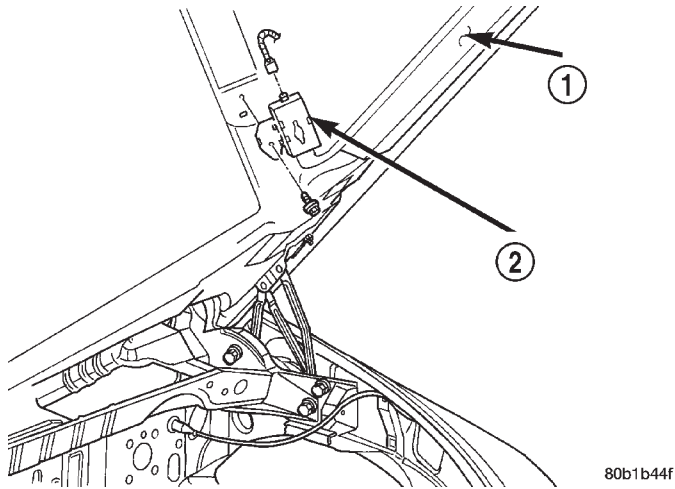

Fig. 9 Underhood Lamp Removal

- 1 - HOOD
- 2 - UNDERHOOD LAMP

INSTALLATION

- (1) Install bulb.
- (2) Install lamp lens.
- (3) Position the underhood lamp on the hood inner panel.
- (4) Install the attaching screw through the lamp and into the hood panel (Fig. 9). Tighten the screw securely.
- (5) Fold lamp housing over and firmly press onto base to snap into place.
- (6) Connect the wire harness connector to the lamp.

DOMELAMP

REMOVAL

- (1) Using a small flat blade, pry the left side (driver's side) of the dome lamp lens downward from dome lamp.
- (2) Allow the lens to hang down, this will disengage the right side of the lamp (passenger's side) from the headliner.
- (3) Pull the right side of the lamp down and slide the lamp to the right.
- (4) Separate the lamp from the headliner.
- (5) Disengage dome lamp wire connector from body wire harness.
- (6) Separate dome lamp from vehicle (Fig. 10) and (Fig. 11).

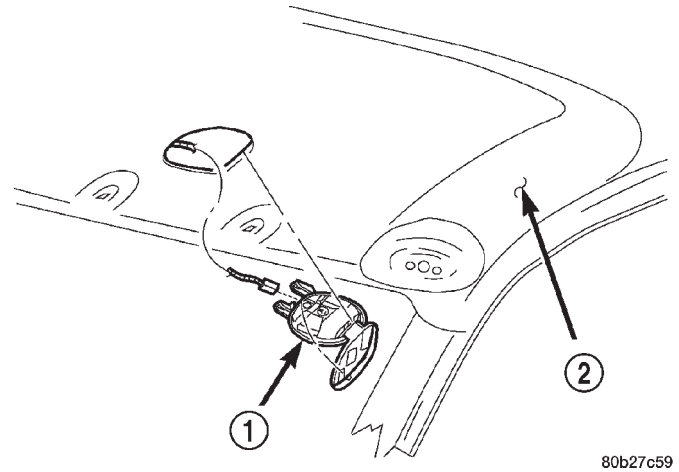

Fig. 10 Front Dome Lamp

- 1 - DOMELAMP
- 2 - HEADLINER

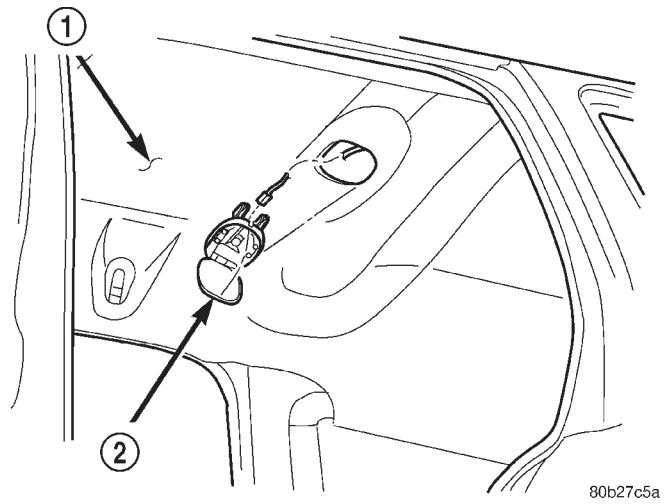

Fig. 11 Rear Dome Lamp

- 1 - HEADLINER
- 2 - DOMELAMP

INSTALLATION

- (1) Position dome lamp at headliner.
- (2) Connect dome lamp wire connector to body wire harness.
- (3) Position the left side of the lamp in the headliner opening and slide lamp to the left.
- (4) Push the right side of the lamp in the headliner opening and push the lamp lens up into the lamp to secure.

2ND SEAT DOMELAMP

REMOVAL

- (1) Using a small flat blade, pry the center rearward edge of the dome/reading lamp lens downward from lamp (Fig. 12).

REMOVAL AND INSTALLATION (Continued)

- (2) Allow the lens to hang down this will disengage the forward edge of the lamp from the headliner.
- (3) Pull the forward edge of the lamp down and slide the lamp forward.
- (4) Separate the lamp from the headliner.
- (5) Disengage lamp wire connector from body wire harness.
- (6) Separate lamp from vehicle (Fig. 13).

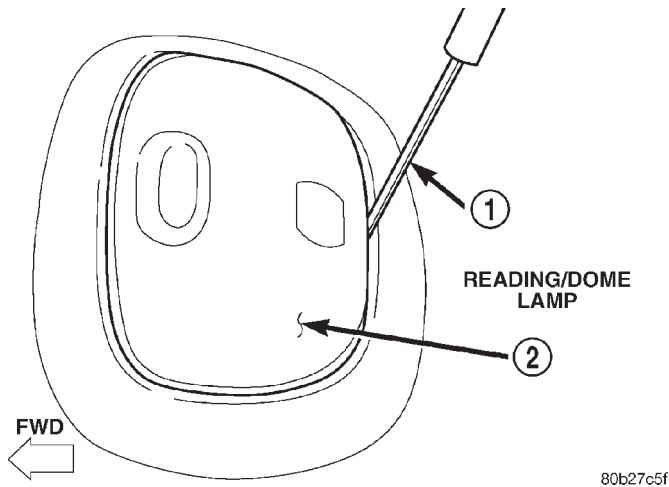

Fig. 12 Lamp Lens

- 1 - FLAT BLADE
2 - LENS

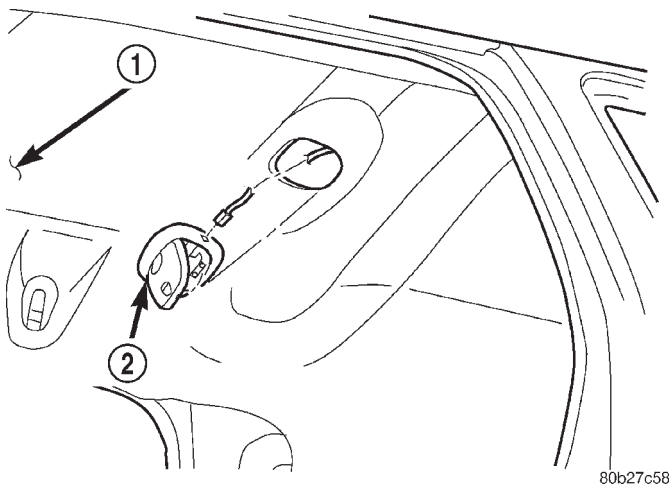

Fig. 13 Dome/Reading Lamp

- 1 - HEADLINER
2 - DOME/READING LAMP

INSTALLATION

- (1) Position lamp at headliner.
- (2) Connect lamp wire connector to body wire harness.
- (3) Position the rearward edge of the lamp in the headliner opening and slide lamp rearward.
- (4) Push the forward edge of the lamp in the headliner opening and push the lamp lens up into the lamp to secure.

OVERHEAD CONSOLE READING LAMP

REMOVAL

- (1) Remove overhead console.
- (2) Remove screws attaching reading lamp to overhead console (Fig. 14).
- (3) Disconnect reading lamp harness connector.
- (4) Separate lamp from vehicle.

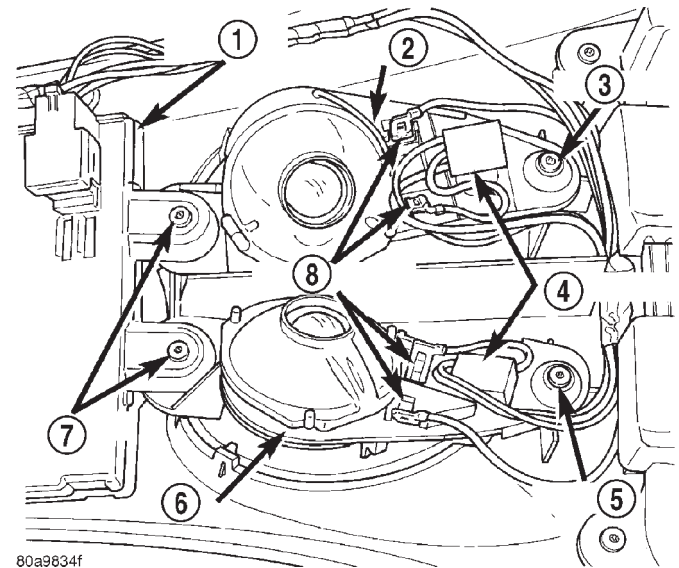

Fig. 14 Overhead Console Reading Lamp

- 1 - DISPLAY MODULE
2 - LAMP
3 - SCREW
4 - SWITCHES
5 - SCREW
6 - LAMP
7 - SCREWS
8 - TERMINALS

INSTALLATION

- (1) Position lamp in vehicle.
- (2) Connect reading lamp harness connector.
- (3) Install screws attaching reading lamp to overhead console.
- (4) Install overhead console.

LAMP SYSTEMS

TABLE OF CONTENTS

page

REMOVAL AND INSTALLATION

DAYTIME RUNNING LAMP MODULE (DRLM) . . . 21

REMOVAL AND INSTALLATION

DAYTIME RUNNING LAMP MODULE (DRLM)

REMOVAL

The Daytime Running Lamp Module is located on the left inner fender.

- (1) Remove the bolt attaching the module to the inner fender (Fig. 1).
- (2) Disconnect the electrical connector.

INSTALLATION

- (1) Connect the electrical connector.
- (2) Insert the tab on the DRLM into the slot on the left inner fender.
- (3) Install the bolt attaching the module to the left inner fender.

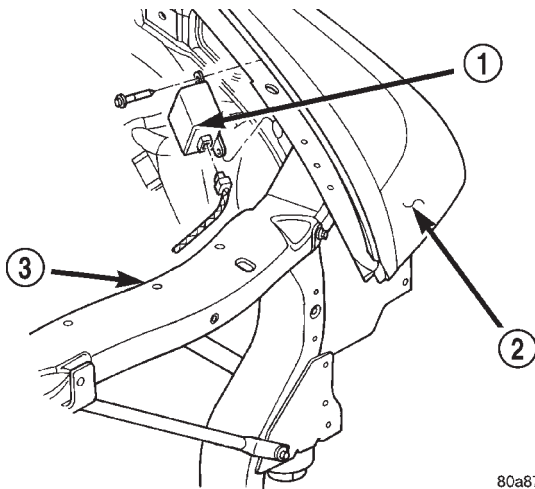

80a8710b

Fig. 1 Daytime Running Lamp Module

- 1 - DAYTIME RUNNING LAMP MODULE
- 2 - LEFT FENDER
- 3 - RADIATOR CLOSURE PANEL

BULB APPLICATION

TABLE OF CONTENTS

| | | | |
|-------------------------|------|---------------------------------|------|
| | page | | page |
| SPECIFICATIONS | | INTERIOR LAMPS | 22 |
| EXTERIOR LAMPS. | 22 | | |

SPECIFICATIONS

EXTERIOR LAMPS

CAUTION: Do not use bulbs that have a higher candle power than the bulb listed in the Bulb Application Table. Damage to lamp can result. Do not touch halogen bulbs with fingers or other oily surfaces. Bulb life will be reduced.

The following Bulb Application Table lists the lamp title on the left side of the column and trade number or part number on the right.

| LAMP | BULB |
|--|-------------|
| Back-up | 3057 |
| Center High Mounted Stop lamp | 922 |
| Fog lamp | 893 |
| Front Side Marker | 194 |
| Front Park/Turn Signal | 3157 |
| Head lamp | 9007 |
| License Plate | 168 |
| Tail, Brake, Turn Signal and Side Marker | 3057 |

INTERIOR LAMPS

CAUTION: Do not use bulbs that have a higher candle power than the bulb listed in the Bulb Application Table. Damage to lamp can result.

Service procedures for most of the lamps in the instrument panel, Instrument cluster and switches are located in Group 8E, Instrument Panel and Gauges. Some components have lamps that can only be serviced by an Authorized Service Center (ASC) after the component is removed from the vehicle.

The following Bulb Application Tables lists the lamp title on the left side of the column and trade number or part number on the right.

| LAMP | BULB |
|-------------------------------|-------------|
| Dome | 579 |
| Dome/Reading | 579 |
| Glove Compartment | 194 |
| Overhead Console | 212-2 |
| Underhood | 105 |
| Underpanel Courtesy | 904 |

INDICATOR LAMPS

| LAMP | BULB |
|---------------------------------|-------------|
| A/C Control | 74 |
| Airbag | PC194 |
| Anti-lock Brake | PC194 |
| Ash Receiver | 161 |
| Brake Warning | PC194 |
| Check Engine | PC194 |
| Cigar Lighter | 161 |
| Engine Oil Pressure | PC194 |
| Fasten Seat Belts | PC194 |
| Four Wheel Drive | 161 |
| Heater Control | 158 |
| High Beam | PC194 |
| Ignition Key | 53 |
| Illumination | PC194 |
| Low Fuel | PC194 |
| Low Washer Fluid | PC194 |
| Maintenance Required | PC194 |
| Radio | ASC |
| Temperature Indicator | PC194 |
| Turn Signal | PC194 |