

OVERHEAD CONSOLE SYSTEMS

TABLE OF CONTENTS

	page		page
DESCRIPTION AND OPERATION		COMPASS DEMAGNETIZING	7
OVERHEAD CONSOLE SYSTEM	1	REMOVAL AND INSTALLATION	
OVERHEAD CONSOLE	1	OVERHEAD CONSOLE READING AND	
COMPASS MINI-TRIP COMPUTER	2	COURTESY LAMP LENS	8
OVERHEAD CONSOLE READING AND		OVERHEAD CONSOLE	9
COURTESY LAMP	3	PAPERCLIP	10
GARAGE DOOR OPENER STORAGE BIN	3	COMPASS MINI-TRIP COMPUTER	11
PAPERCLIP	4	OVERHEAD CONSOLE READING AND	
SUNGLASSES STORAGE BIN	4	COURTESY LAMP HOUSING	11
AMBIENT TEMPERATURE SENSOR	4	SUNGLASSES STORAGE BIN	12
DIAGNOSIS AND TESTING		GARAGE DOOR OPENER STORAGE BIN	
COMPASS MINI-TRIP COMPUTER	5	DOOR	13
AMBIENT TEMPERATURE SENSOR	6	AMBIENT TEMPERATURE SENSOR	13
SERVICE PROCEDURES		SPECIAL TOOLS	
COMPASS VARIATION ADJUSTMENT	6	OVERHEAD CONSOLE SYSTEMS	14
COMPASS CALIBRATION	6		

DESCRIPTION AND OPERATION

OVERHEAD CONSOLE SYSTEM

DESCRIPTION

An overhead console unit is an available factory-installed option on this model. The overhead console unit features a garage door opener storage bin, a sunglasses storage bin, two reading and courtesy lamps and either a standard paperclip or an optional compass mini-trip computer. See the owner's manual in the vehicle glove box for more information on the features, use and operation of all of the overhead console components and systems. Refer to **Overhead Console** in the Contents of Group 8W - Wiring Diagrams for complete circuit diagrams.

OVERHEAD CONSOLE

DESCRIPTION

The overhead console (Fig. 1) for this model includes two front-mounted reading and courtesy lamps, a garage door opener storage bin, a sunglasses storage bin and either a standard paperclip or an optional compass mini-trip computer.

The overhead console is secured with two snap clips at the rear and a single screw at the front to the overhead console mounting bracket. The front of the overhead console mounting bracket is secured to

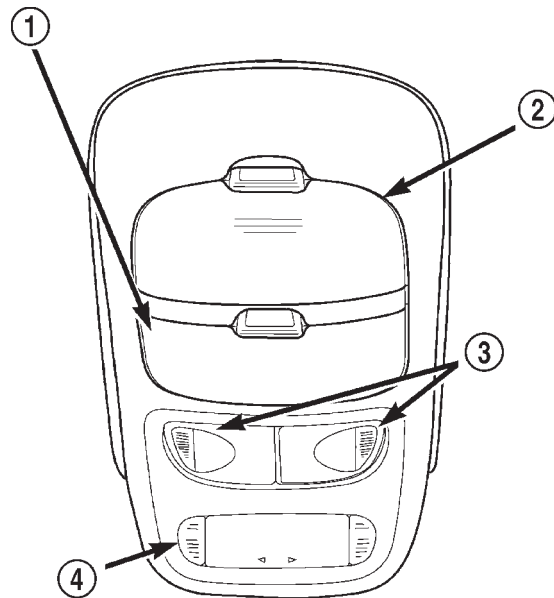

80bce961

Fig. 1 Overhead Console

- 1 - SUNGLASSES STORAGE BIN
- 2 - GARAGE DOOR OPENER STORAGE BIN
- 3 - READING AND COURTESY LAMPS
- 4 - PAPERCLIP OR COMPASS MINI-TRIP COMPUTER

the roof header near the windshield with two screws, and the rear of the bracket is secured with double-

DESCRIPTION AND OPERATION (Continued)

faced tape to the inside surface of the roof panel. A single electrical connection joins the overhead console wire harness to the roof wire harness.

Following are general descriptions of the major components used in the overhead console. See the owner's manual in the vehicle glove box for more information on the use and operation of the various overhead console features.

COMPASS MINI-TRIP COMPUTER

DESCRIPTION

The compass mini-trip computer is located in the overhead console on models equipped with this option. The compass mini-trip computer units include the electronic control module, a Vacuum-Fluorescent Display (VFD), a compass sensor unit and two push button function switches.

The compass mini-trip computer module contains a central processing unit and interfaces with other electronic modules in the vehicle on the Chrysler Collision Detection (CCD) data bus network. The CCD data bus network allows the sharing of sensor information. This helps to reduce wire harness complexity, reduce internal controller hardware, and reduce component sensor current loads. At the same time, this system provides increased reliability, enhanced diagnostics, and allows the addition of many new feature capabilities.

The compass mini-trip computer provides several electronic functions and features. Some of the functions and features that the compass mini-trip computer module supports and/or controls, include the following display options:

- **Compass and temperature** - provides the outside temperature and one of eight compass readings to indicate the direction the vehicle is facing.
- **Trip odometer (TRIP ODO)** - shows the distance travelled since the last trip computer reset.
- **Average fuel economy (AVG ECO)** - shows the average fuel economy since the last trip computer reset.
- **Instant fuel economy (ECO)** - shows the present fuel economy based upon the current vehicle distance and fuel used information.
- **Distance to empty (DTE)** - shows the estimated distance that can be travelled with the fuel remaining in the fuel tank. This estimated distance is computed using the average miles-per-gallon from the last 30 gallons of fuel used.
- **Elapsed time (ET)** - shows the accumulated ignition-on time since the last trip computer reset.
- **Blank screen** - the compass mini-trip VFD is turned off.

The ambient temperature sensor is hard wired to the compass mini-trip computer module. Data input

for all other compass mini-trip computer functions, including VFD dimming level, is received through CCD data bus messages. The compass mini-trip computer uses its internal programming and all of these inputs to calculate and display the requested data. If the data displayed is incorrect, perform the self-diagnostic tests as described in this group. If these tests prove inconclusive, the use of a DRB scan tool and the proper Diagnostic Procedures manual are recommended for further testing of the compass mini-trip computer module and the CCD data bus.

The compass mini-trip computer module cannot be repaired, and is available for service only as a unit. This unit includes the push button switches and the plastic module and display lens. If any of these components is faulty or damaged, the complete compass mini-trip computer module must be replaced.

COMPASS

While in the compass/temperature mode, the compass will display the direction in which the vehicle is pointed using the eight major compass headings (Examples: north is N, northeast is NE). The self-calibrating compass unit requires no adjusting in normal use. The only calibration that may prove necessary is to drive the vehicle in three complete circles, on level ground, in not less than forty-eight seconds. This will reorient the compass unit to its vehicle.

The compass unit also will compensate for magnetism the body of the vehicle may acquire during normal use. However, avoid placing anything magnetic directly on the roof of the vehicle. Magnetic mounts for an antenna, a repair order hat, or a funeral procession flag can exceed the compensating ability of the compass unit if placed on the roof panel. Magnetic bit drivers used on the fasteners that hold the overhead console assembly to the roof header can also affect compass operation. If the vehicle roof should become magnetized, the demagnetizing and calibration procedures found in this group may be required to restore proper compass operation.

THERMOMETER

The thermometer displays the outside ambient temperature in whole degrees. The temperature display can be changed from Fahrenheit to Celsius using the U.S./Metric push button. The displayed temperature is not an instant reading of conditions, but an average temperature. It may take the thermometer display several minutes to respond to a major temperature change, such as driving out of a heated garage into winter temperatures.

When the ignition switch is turned to the Off position, the last displayed temperature reading stays in the thermometer unit memory. When the ignition

DESCRIPTION AND OPERATION (Continued)

switch is turned to the On position again, the thermometer will display the memory temperature if the engine coolant temperature is above about 52° C (125° F). If the engine coolant temperature is below about 52° C (125° F), the thermometer will display the actual temperature sensed by the ambient temperature sensor. The thermometer temperature display update interval varies with the vehicle speed.

The thermometer function is supported by an ambient temperature sensor. The sensor is mounted outside the passenger compartment near the front and center of the vehicle, and is hard wired to the module. The ambient temperature sensor is available as a separate service item.

OPERATION

The compass mini-trip computer only operates with the ignition switch in the On position. When the ignition switch is turned to the On position, all of the segments in the compass mini-trip computer VFD will be turned off for one second, then the display will return to the last function being displayed before the ignition was turned to the Off position. With the ignition switch in the On position, momentarily depressing and releasing the Step push button switch will cause the compass-mini-trip computer to change its mode of operation, and momentarily depressing and releasing the U.S./Metric push button will cause the unit to toggle between U.S. and Metric measurements.

This compass mini-trip computer features several functions that can be reset. If both the Step and U.S./Metric push buttons are depressed at the same time for more than one second with the ignition switch in the On position, the trip computer information that can be reset is reset. However, the reset will only occur if the function currently displayed is a function that can be reset. The functions that can be reset are: TRIP ODO, AVG ECO, and ET.

For more information on the features and control functions of the compass mini-trip computer, see the owner's manual in the vehicle glove box.

OVERHEAD CONSOLE READING AND COURTESY LAMP

DESCRIPTION

The overhead console in this vehicle is equipped with two individual reading and courtesy lamps. The lamp lenses are the only visible components of these lamps. The reading and courtesy lamp lenses are mounted in the overhead console housing between the compass mini-trip computer display and the sunglasses storage bin. Each lamp has its own switch, bulb, and lens; but both lamps share a common lamp housing within the overhead console.

The overhead console reading and courtesy lamps operate on battery current that is provided at all times, regardless of the ignition switch position. The ground feed for the lamps is switched through the integral reading and courtesy lamp switches or through the door jamb switches. Each lamp is designed and aimed to provide illumination that will be directed only to that side of the vehicle on which the lamp is located.

The reading and courtesy lamp lenses, bulbs and the lamp housing are available for service replacement. The reading and courtesy lamp switches, bulb holders and wiring are only available as part of the overhead console wire harness. If either of the lamp switches or bulb holders is faulty or damaged, the entire overhead console wire harness assembly must be replaced.

For service of the reading and courtesy lamp bulbs, refer to **Overhead Console Reading Lamp Bulbs** in the Removal and Installation section of Group 8L - Lamps. For diagnosis of the reading and courtesy lamps, refer to **Lamp Diagnosis** in the Diagnosis and Testing section of Group 8L - Lamps. For complete circuit diagrams, refer to **Overhead Console** in the Contents of Group 8W - Wiring Diagrams.

OPERATION

All reading and courtesy lamps located in the overhead console are activated by the door jamb switches. When all of the doors are closed, these lamps can be individually activated by depressing the corresponding lens. When any door is open, depressing the lamp lenses to activate the lamp switches will not turn the lamps off.

See the owner's manual in the vehicle glove box for more information on the use and operation of the overhead console reading and courtesy lamps.

GARAGE DOOR OPENER STORAGE BIN

DESCRIPTION

A compartment near the rear of the overhead console is designed to hold most garage door opener remote control transmitters. The door for the garage door opener compartment features a spring-loaded latch mechanism and has a small depression with tactile ribs just forward of the latch. The transmitter is mounted within the compartment with an adhesive-backed hook and loop fastener patch and, when the compartment is closed, the depressed area of the compartment door is pressed upward to actuate the transmitter.

A transmitter mounting kit including the adhesive-backed hook and loop fastener material and additional adapter pegs is available for service. The garage door opener storage bin door is also available

DESCRIPTION AND OPERATION (Continued)

for service replacement. The door unit includes the spring-loaded latch mechanism. If any of these components is damaged or faulty, the garage door opener storage bin door unit must be replaced.

OPERATION

The garage door opener storage compartment door is opened by pressing the spring-loaded latch towards the front of the vehicle. When the compartment door is opened, the garage door opener transmitter can be installed in the compartment using the adhesive-backed hook and loop fastener material provided.

With the transmitter mounted in the storage bin, adapter pegs located on the inside of the garage door opener door are selected and mounted on one of several posts on the back side of the door. The adapter pegs can be stacked if additional length is required. The combination of the adapter peg length and the peg location selected must be suitable to depress the button of the transmitter when the center of the garage door opener storage bin door is depressed. When the proper combination has been selected, the compartment door is closed and need not be reopened except to replace the transmitter batteries.

See the owner's manual in the vehicle glove box for more information on the use and operation of the overhead console garage door opener storage bin.

PAPERCLIP**DESCRIPTION**

A paperclip is standard equipment on the base version of the overhead console. The paperclip provides a convenient place for storage and easy retrieval of notes, maps, toll tickets or stubs and other paper items that may be required or desired while driving. The paperclip is located near the front of the overhead console and is secured in the overhead console housing by four screws.

The paperclip is available for service replacement, but it cannot be adjusted or repaired. If the paperclip is damaged or faulty it must be replaced.

SUNGLASSES STORAGE BIN**DESCRIPTION**

A sunglasses storage bin is included in the overhead console. The storage bin is located near the center of the overhead console and is held in the closed position by a spring-loaded latch mechanism that is integral to the storage bin door. The interior of the bin is lined with a foam rubber padding material to protect the sunglasses from being scratched. A damper spring is snapped onto the pivot shaft of the sunglasses storage bin door. The damper spring engages two flats on the shaft and is anchored in a

slot in the rear flange of the overhead console reading and courtesy lamp housing to provide a smooth opening action and an open detent position for the storage bin unit.

The sunglasses storage bin and door unit is available for service replacement. The bin and door unit includes the spring-loaded latch mechanism, the bin liner and the damper spring. If any of these components is damaged or faulty, the sunglasses storage bin and door unit must be replaced.

OPERATION

The sunglasses storage bin is opened by pressing the latch on the rear edge of the door towards the front of the vehicle, then pulling the bin downward to the open detent position. The spring-loaded latch mechanism on the sunglasses bin door will automatically engage when the bin is closed. See the owner's manual in the vehicle glove box for more information on the use and operation of the sunglasses storage bin.

AMBIENT TEMPERATURE SENSOR**DESCRIPTION**

Ambient air temperature is monitored by the compass mini-trip computer module through the ambient temperature sensor. The ambient temperature sensor is a variable resistor mounted to a bracket that is secured with a screw to the right side of the radiator yoke, behind the radiator grille and in front of the engine compartment.

For complete circuit diagrams, refer to **Overhead Console** in the Contents of Group 8W - Wiring Diagrams. The ambient temperature sensor cannot be adjusted or repaired and, if faulty or damaged, it must be replaced.

OPERATION

The ambient temperature sensor is a variable resistor that operates on a five-volt reference signal sent to it by the compass mini-trip computer module. The resistance in the sensor changes as temperature changes, changing the temperature sensor signal circuit voltage to the compass mini-trip computer module. Based upon the resistance in the sensor, the compass mini-trip computer module senses a specific voltage on the temperature sensor signal circuit, which it is programmed to correspond to a specific temperature.

DIAGNOSIS AND TESTING

COMPASS MINI-TRIP COMPUTER

If the problem with the compass mini-trip computer module is an “OC” or “SC” in the compass/thermometer display, refer to **Ambient Temperature Sensor** in the Diagnosis and Testing section of this group. If the problem with the compass mini-trip computer module is an inaccurate or scrambled display, refer to **Self-Diagnostic Test** in the Diagnosis and Testing section of this group. If the problem with the compass mini-trip computer module is incorrect Vacuum Fluorescent Display (VFD) dimming levels, use a DRB scan tool and the proper Diagnostic Procedures manual to test for the correct dimming message inputs being received from the instrument cluster over the Chrysler Collision Detection (CCD) data bus. If the problem is a no-display condition, use the following procedures. For complete circuit diagrams, refer to **Overhead Console** in the Contents of Group 8W - Wiring Diagrams.

(1) Check the fused ignition switch output (run/start) fuse in the junction block. If OK, go to Step 2. If not OK, repair the shorted circuit or component as required and replace the faulty fuse.

(2) Turn the ignition switch to the On position. Check for battery voltage at the fused ignition switch output (run/start) fuse in the junction block. If OK, go to Step 3. If not OK, repair the open fused ignition switch output (run/start) circuit to the ignition switch as required.

(3) Turn the ignition switch to the Off position. Disconnect and isolate the battery negative cable. Remove the overhead console. Check for continuity between the ground circuit cavities of the roof wire harness connector for the overhead console and a good ground. There should be continuity. If OK, go to Step 4. If not OK, repair the open ground circuit to ground as required.

(4) Connect the battery negative cable. Turn the ignition switch to the On position. Check for battery voltage at the fused ignition switch output (run/start) circuit cavity of the roof wire harness connector for the overhead console. If OK, refer to **Self-Diagnostic Test** in the Diagnosis and Testing section of this group for further diagnosis of the compass mini-trip computer module and the CCD data bus. If not OK, repair the open fused ignition switch output (run/start) circuit to the junction block fuse as required.

SELF-DIAGNOSTIC TEST

A self-diagnostic test is used to determine that the compass mini-trip computer module is operating properly electrically. Initiate the self-diagnostic test as follows:

(1) With the ignition switch in the Off position, simultaneously depress and hold the Step button and the U.S./Metric button.

(2) Turn the ignition switch to the On position.

(3) Continue to hold both buttons depressed until the compass mini-trip computer module enters the display segment test. In this test, all of the Vacuum Fluorescent Display (VFD) segments are lighted while the compass mini-trip computer module performs the following checks:

- a. Microprocessor compass circuit test
- b. Non-volatile memory read/write test
- c. Microprocessor ROM verification test
- d. CCD communications test.

(4) Following completion of these tests, the compass mini-trip computer will return to normal operation or display one of two messages: “FAIL” or “CCd.” Respond to these test results as follows:

a. If no test result message is displayed, but compass mini-trip computer operation is still improper, the use of a DRB scan tool and the proper Diagnostic Procedures manual are required for further diagnosis.

b. If the “FAIL” message is displayed, the compass mini-trip computer module is faulty and must be replaced.

c. If the “CCd” message is displayed, the use of a DRB scan tool and the proper Diagnostic Procedures manual are required for further diagnosis.

d. If any VFD segment should fail to light during the display segment test, the compass mini-trip computer module is faulty and must be replaced.

(5) If all tests are passed, or if the ignition switch is turned to the Off position, the compass mini-trip computer module will automatically return to normal operation.

NOTE: If the compass functions, but accuracy is suspect, it may be necessary to perform a variation adjustment. This procedure allows the compass unit to accommodate variations in the earth’s magnetic field strength, based on geographic location. Refer to **Compass Variation Adjustment** in the Service Procedures section of this group.

NOTE: If the compass reading has blanked out, and only “CAL” appears in the display, demagnetizing may be necessary to remove excessive residual magnetic fields from the vehicle. Refer to **Compass Demagnetizing** in the Service Procedures section of this group.

DIAGNOSIS AND TESTING (Continued)

AMBIENT TEMPERATURE SENSOR

The thermometer function is supported by the ambient temperature sensor, a wiring circuit, and a portion of the compass mini-trip computer module. If any portion of the ambient temperature sensor circuit fails, the compass/thermometer display function will self-diagnose the circuit. An "SC" (short circuit) will appear in the display in place of the temperature, when the sensor is exposed to temperatures above 110° C (230° F), or if the sensor circuit is shorted. An "OC" (open circuit) will appear in the display in place of the temperature, when the sensor is exposed to temperatures below -50° C (-58° F), or if the sensor circuit is open.

The ambient temperature sensor circuit can also be diagnosed using the following Sensor Test, and Sensor Circuit Test. If the temperature sensor and circuit are confirmed to be OK, but the temperature display is inoperative or incorrect, refer to **Compass Mini-Trip Computer** in the Diagnosis and Testing section of this group. For complete circuit diagrams, refer to **Overhead Console** in the Contents of Group 8W - Wiring Diagrams.

SENSOR TEST

(1) Turn the ignition switch to the Off position. Disconnect and isolate the battery negative cable. Disconnect the ambient temperature sensor wire harness connector.

(2) Measure the resistance of the ambient temperature sensor. At -40° C (-40° F), the sensor resistance is 336 kilohms. At 55° C (131° F), the sensor resistance is 2.488 kilohms. The sensor resistance should read between these two values. If OK, refer to **Sensor Circuit Test** in the Diagnosis and Testing section of this group. If not OK, replace the faulty ambient temperature sensor.

SENSOR CIRCUIT TEST

(1) Turn the ignition switch to the Off position. Disconnect and isolate the battery negative cable. Disconnect the ambient temperature sensor wire harness connector and the overhead console wire harness connector.

(2) Connect a jumper wire between the two terminals in the body half of the ambient temperature sensor wire harness connector.

(3) Check for continuity between the sensor return circuit and the ambient temperature sensor signal circuit cavities of the roof wire harness overhead console connector. There should be continuity. If OK, go to Step 4. If not OK, repair the open sensor return circuit or ambient temperature sensor signal circuit to the ambient temperature sensor as required.

(4) Remove the jumper wire from the body half of the ambient temperature sensor wire harness con-

necter. Check for continuity between the sensor return circuit cavity of the roof wire harness overhead console connector and a good ground. There should be no continuity. If OK, go to Step 5. If not OK, repair the shorted sensor return circuit as required.

(5) Check for continuity between the ambient temperature sensor signal circuit cavity of the roof wire harness overhead console connector and a good ground. There should be no continuity. If OK, refer to **Compass Mini-Trip Computer** in the Diagnosis and Testing section of this group. If not OK, repair the shorted ambient temperature sensor signal circuit as required.

SERVICE PROCEDURES**COMPASS VARIATION ADJUSTMENT**

Compass variance, also known as magnetic declination, is the difference in angle between magnetic north and true geographic north. In some geographic locations, the difference between magnetic and geographic north is great enough to cause the compass to give false readings. If this problem occurs, the compass variance must be set.

To set the compass variance:

(1) Using the Variance Settings map, find your geographic location and note the zone number (Fig. 2).

(2) Turn the ignition switch to the On position. If the compass/temperature data is not currently being displayed, momentarily depress and release the Step push button to step through the display options until you have reached the compass/temperature display.

(3) Depress both the U.S./Metric, and the Step push buttons and hold the buttons down until "VAR" appears in the display. This takes about five seconds.

(4) Release both of the push buttons. "VAR" along with the current variance zone will appear in the display.

(5) Momentarily depress and release the U.S./Metric push button to step through the zone numbers, until the zone number for your geographic location appears in the display.

(6) Momentarily depress and release the Step push button to enter the displayed zone number into the compass unit memory.

(7) Confirm that the correct directions are now indicated by the compass.

COMPASS CALIBRATION

CAUTION: Do not place any external magnets, such as magnetic roof mount antennas, in the vicinity of the compass. Do not use magnetic tools when servicing the overhead console.

SERVICE PROCEDURES (Continued)

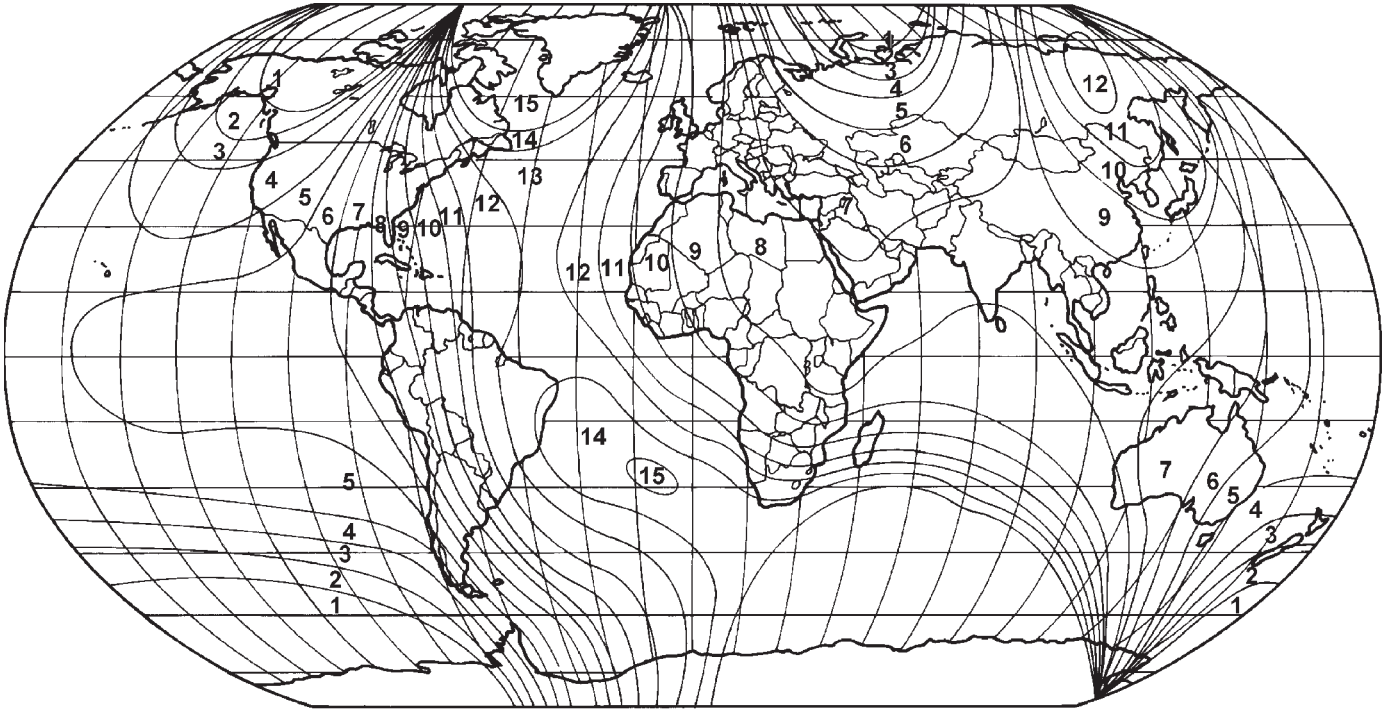

80a13863

Fig. 2 Variance Settings

The electronic compass unit features a self-calibrating design, which simplifies the calibration procedure. This feature automatically updates the compass calibration while the vehicle is being driven. This allows the compass unit to compensate for small changes in the residual magnetism that the vehicle may acquire during normal use. If the compass readings appear to be erratic or out of calibration, perform the following calibration procedure. Also, new service replacement compass mini-trip computer modules must have their compass calibrated using this procedure. Do not attempt to calibrate the compass near large metal objects such as other vehicles, large buildings, or bridges; or, near overhead or underground power lines.

NOTE: Whenever the compass is calibrated manually, the variation number must also be reset. See **Compass Variation Adjustment** in the **Service Procedures** section of this group.

Calibrate the compass manually as follows:

(1) Turn the ignition switch to the On position. If the compass/temperature data is not currently being displayed, momentarily depress and release the Step push button to step through the display options until you have reached the compass/temperature display.

(2) Depress both the U.S./Metric and the Step push buttons. Hold the push buttons down until "CAL" appears in the display. This takes about ten

seconds, and appears about five seconds after "VAR" is displayed.

(3) Release both of the push buttons.

(4) Drive the vehicle on a level surface, away from large metal objects and power lines, through three or more complete circles in not less than 48 seconds. The "CAL" message will disappear from the display to indicate that the compass is now calibrated.

NOTE: If the "CAL" message remains in the display, either there is excessive magnetism near the compass, or the unit is faulty. Repeat the calibration procedure at least one more time.

NOTE: If the wrong direction is still indicated in the compass display, the area selected for calibration may be too close to a strong magnetic field. Repeat the calibration procedure in another location.

COMPASS DEMAGNETIZING

A degaussing tool (Special Tool 6029) is used to demagnetize, or degauss, the overhead console forward mounting screw and the roof panel above the overhead console. Equivalent units must be rated as continuous duty for 110/115 volts and 60 Hz. They must also have a field strength of over 350 gauss at 7 millimeters (0.25 inch) beyond the tip of the probe.

To demagnetize the roof panel and the overhead console forward mounting screw, proceed as follows:

SERVICE PROCEDURES (Continued)

(1) Be certain that the ignition switch is in the Off position, before you begin the demagnetizing procedure.

(2) Connect the degaussing tool to an electrical outlet, while keeping the tool at least 61 centimeters (2 feet) away from the compass unit.

(3) Slowly approach the head of the overhead console forward mounting screw with the degaussing tool connected.

(4) Contact the head of the screw with the plastic coated tip of the degaussing tool for about two seconds.

(5) With the degaussing tool still energized, slowly back it away from the screw. When the tip of the tool is at least 61 centimeters (2 feet) from the screw head, disconnect the tool.

(6) Place a piece of paper approximately 22 by 28 centimeters (8.5 by 11 inches), oriented on the vehicle lengthwise from front to rear, on the center line of the roof at the windshield header (Fig. 3). The purpose of the paper is to protect the roof panel from scratches, and to define the area to be demagnetized.

(7) Connect the degaussing tool to an electrical outlet, while keeping the tool at least 61 centimeters (2 feet) away from the compass unit.

(8) Slowly approach the center line of the roof panel at the windshield header, with the degaussing tool connected.

(9) Contact the roof panel with the plastic coated tip of the degaussing tool. Be sure that the template is in place to avoid scratching the roof panel. Using a slow, back-and-forth sweeping motion, and allowing 13 millimeters (0.50 inch) between passes, move the tool at least 11 centimeters (4 inches) to each side of the roof center line, and 28 centimeters (11 inches) back from the windshield header.

(10) With the degaussing tool still energized, slowly back it away from the roof panel. When the tip of the tool is at least 61 centimeters (2 feet) from the roof panel, disconnect the tool.

(11) Calibrate the compass and adjust the compass variance. Refer to **Compass Variation Adjustment** and **Compass Calibration** in the Service Procedures section of this group for the procedures.

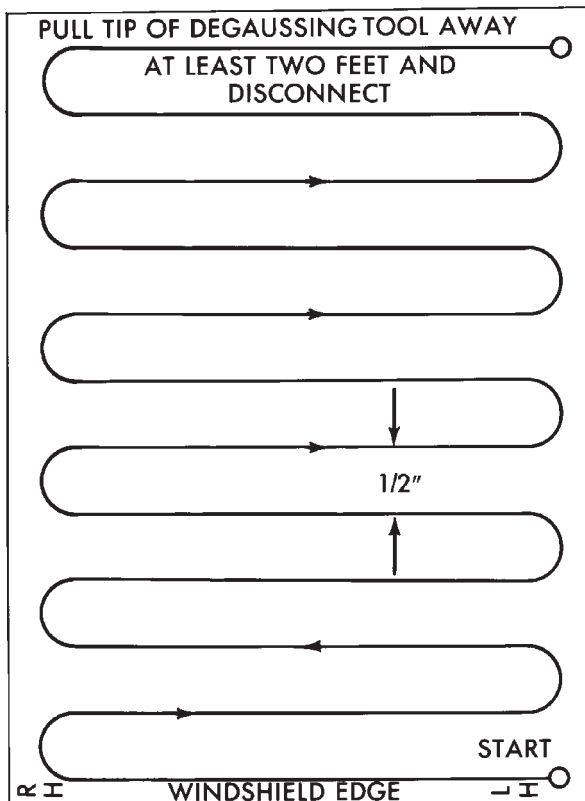

J908E-27

Fig. 3 Roof Demagnetizing Pattern

REMOVAL AND INSTALLATION

OVERHEAD CONSOLE READING AND COURTESY LAMP LENS

REMOVAL

(1) Disconnect and isolate the battery negative cable.

(2) Insert a long, narrow, flat-bladed tool between the edge of the reading and courtesy lamp lens and the overhead console housing just inboard of the lens pivots (Fig. 4).

(3) Gently pry downward against the reading and courtesy lamp lens until the pivot of the lens is disengaged from the pivot pin in the lens opening of the overhead console housing.

(4) Repeat the procedure to disengage the second lens pivot from its pivot pin.

(5) Pull the pivot end (inboard side) of the reading and courtesy lamp lens horizontally inboard far enough to disengage the switch actuator tab on the outboard side of the lens from the overhead console housing.

(6) Remove the reading and courtesy lamp lens from the overhead console housing.

REMOVAL AND INSTALLATION (Continued)

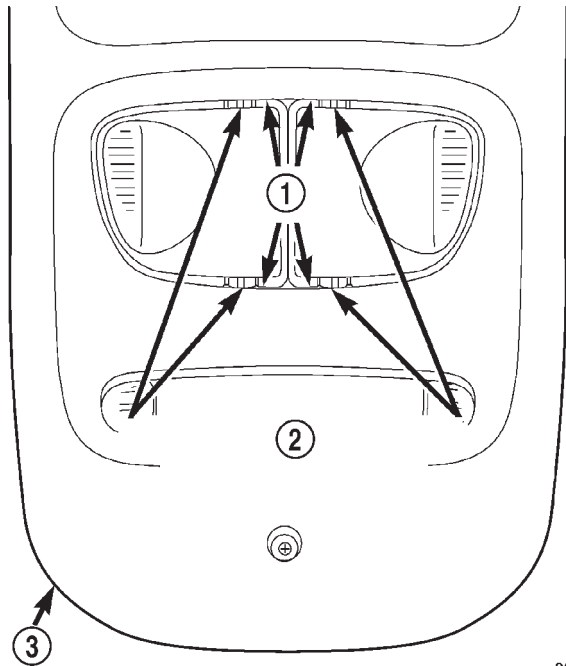

80ba77ce

Fig. 4 Overhead Console Reading and Courtesy Lamp Lens Remove/Install

- 1 - PRY HERE
- 2 - READING AND COURTESY LAMP LENS PIVOTS
- 3 - OVERHEAD CONSOLE

INSTALLATION

- (1) Position the switch actuator tab on the outboard side of the reading and courtesy lamp lens into the lens opening of the overhead console housing. The lens actuator tab should be positioned directly over the switch plunger, which is located just outboard of the lens opening.
- (2) Align the two pivots on the inboard side of the reading and courtesy lamp lens with the two pivot pins on the inboard end of the lens opening in the overhead console housing.
- (3) Push firmly and evenly upward on the reading and courtesy lamp lens directly over each of the two pivots until they snap into place over the pivot pins in the lens opening of the overhead console housing.
- (4) Reconnect the battery negative cable.

OVERHEAD CONSOLE

REMOVAL

OVERHEAD CONSOLE

- (1) Disconnect and isolate the battery negative cable.

- (2) Remove the screw that secures the front of the overhead console to the front of the overhead console bracket (Fig. 5).

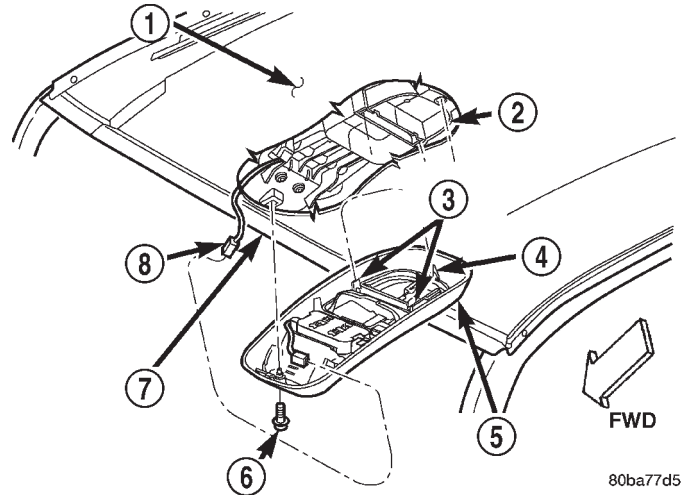

80ba77d5

Fig. 5 Overhead Console Remove/Install

- 1 - HEADLINER
- 2 - BRACKET
- 3 - SNAP CLIP (2)
- 4 - LOCATING PIN
- 5 - OVERHEAD CONSOLE
- 6 - SCREW
- 7 - FRONT HEADER
- 8 - ROOF WIRE HARNESS CONNECTOR

- (3) Insert the fingertips of both hands between the headliner and the sides of the overhead console housing in the area between the garage door opener storage bin and the sunglasses storage bin.
- (4) Pull downward on the sides of the overhead console housing firmly and evenly to disengage the two snap clips that secure the rear of the unit from their receptacles in the overhead console bracket.
- (5) Lower the overhead console from the headliner far enough to access the wire harness connector.
- (6) Disconnect the roof wire harness connector from the overhead console wire harness connector.
- (7) Remove the overhead console from the headliner.

OVERHEAD CONSOLE BRACKET

- (1) Disconnect and isolate the battery negative cable.
- (2) Remove the overhead console from the overhead console bracket. Refer to **Overhead Console** in the Removal and Installation section of this group for the procedures.

REMOVAL AND INSTALLATION (Continued)

(3) Remove the headliner from the roof panel. Refer to **Headliner** in the Removal and Installation section of Group 23 - Body for the procedures.

(4) Remove the two screws that secure the front of the overhead console bracket to the roof front header (Fig. 6).

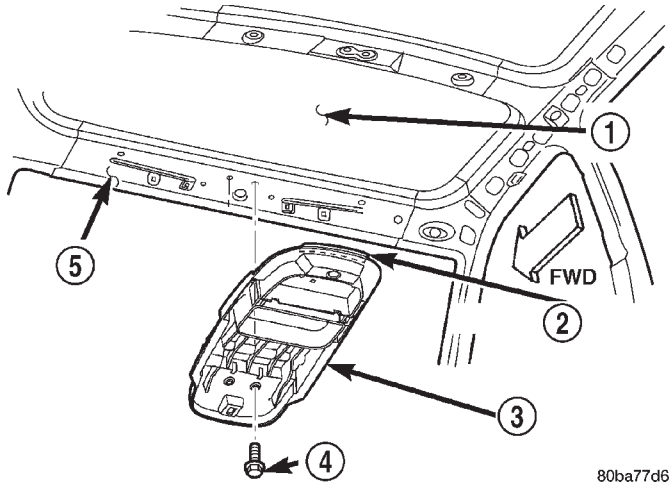

Fig. 6 Overhead Console Bracket Remove/Install

- 1 - ROOF PANEL
- 2 - DOUBLE-FACED TAPE
- 3 - OVERHEAD CONSOLE BRACKET
- 4 - SCREW (2)
- 5 - FRONT HEADER

(5) Using a sharp utility knife, cut through the double-faced tape that secures the rear flange of the overhead console bracket to the roof panel.

(6) Remove the overhead console bracket from the roof panel.

INSTALLATION

OVERHEAD CONSOLE

(1) Position the overhead console near the mounting location on the headliner.

(2) Reconnect the roof wire harness connector to the overhead console wire harness connector.

(3) Align the locating pin on the rear of the overhead console housing with the receptacle in the rear of the overhead console bracket.

(4) Align the two snap clips on the overhead console housing with their receptacles in the overhead console bracket.

(5) Push upward firmly and evenly on the sides of the overhead console housing over both of the snap clip locations until each of the two snap clips is fully engaged with its receptacle in the overhead console bracket.

(6) Install and tighten the screw that secures the front of the overhead console housing to the overhead console bracket. Tighten the screw to 1.9 N·m (17 in. lbs.).

(7) Reconnect the battery negative cable.

OVERHEAD CONSOLE BRACKET

(1) Remove any remnants of the old double-faced tape from the roof panel and the rear flange of the overhead console bracket and clean these areas with a suitable solvent to remove any traces of grease, oil or adhesive residue. When installing the overhead console bracket, always apply a new piece of double-faced tape to the rear flange of the bracket.

(2) Align the two locating pins on the front of the overhead console bracket with the receptacles in the roof front header.

(3) Lower the rear flange of the overhead console bracket from the roof panel far enough to access and remove the release paper from the double-faced tape.

(4) Push upward firmly and evenly on the rear flange of the overhead console bracket over the double-faced tape to ensure complete adhesion to the roof panel.

(5) Install and tighten the two screws that secure the front of the overhead console bracket to the roof front header. Tighten the screws to 2.2 N·m (20 in. lbs.).

(6) Install the headliner onto the roof panel. Refer to **Headliner** in the Removal and Installation section of Group 23 - Body for the procedures.

(7) Install the overhead console onto the overhead console bracket. Refer to **Overhead Console** in the Removal and Installation section of this group for the procedures.

(8) Reconnect the battery negative cable.

PAPERCLIP

REMOVAL

(1) Disconnect and isolate the battery negative cable.

(2) Remove the overhead console from the headliner. Refer to **Overhead Console** in the Removal and Installation section of this group for the procedures.

(3) Remove the four screws that secure the paperclip to the overhead console housing.

(4) Pull the paperclip away from the overhead console far enough to access the wire harness connectors.

REMOVAL AND INSTALLATION (Continued)

(5) Disengage the overhead console wire harness connector from the mount on the paperclip by pushing the connector firmly toward the left side of the overhead console housing.

(6) Remove the paperclip from the overhead console housing.

INSTALLATION

(1) Position the paperclip onto the overhead console housing.

(2) Engage the overhead console wire harness connector onto the mount on the paperclip by aligning the channels on the connector with the tab on the mount and pushing the connector firmly toward the right side of the overhead console housing.

(3) Install and tighten the four screws that secure the paperclip to the overhead console housing. Tighten the screws to 2.2 N·m (20 in. lbs.).

(4) Install the overhead console onto the headliner. Refer to **Overhead Console** in the Removal and Installation section of this group for the procedures.

(5) Reconnect the battery negative cable.

COMPASS MINI-TRIP COMPUTER

REMOVAL

(1) Disconnect and isolate the battery negative cable.

(2) Remove the overhead console from the headliner. Refer to **Overhead Console** in the Removal and Installation section of this group for the procedures.

(3) Remove the four screws that secure the compass mini-trip computer module to the overhead console housing (Fig. 7).

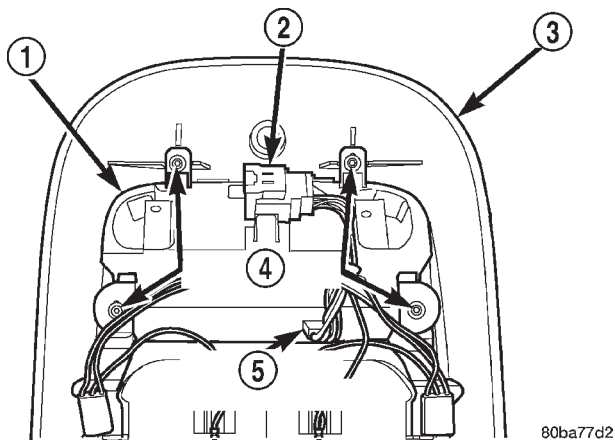

Fig. 7 Compass Mini-Trip Computer Remove/Install

- 1 - COMPASS MINI-TRIP COMPUTER MODULE
- 2 - OVERHEAD CONSOLE WIRE HARNESS CONNECTOR
- 3 - OVERHEAD CONSOLE HOUSING
- 4 - SCREW (4)
- 5 - COMPUTER CONNECTOR

(4) Pull the compass mini-trip computer module away from the overhead console far enough to access the wire harness connectors.

(5) Disengage the overhead console wire harness connector from the mount on the compass mini-trip computer module housing by pushing the connector firmly toward the left side of the overhead console housing.

(6) Disconnect the overhead console wire harness connector from the compass mini-trip computer module connector receptacle.

(7) Remove the compass mini-trip computer module from the overhead console housing.

INSTALLATION

(1) Position the compass mini-trip computer module onto the overhead console housing.

(2) Reconnect the overhead console wire harness connector to the compass mini-trip computer module connector receptacle.

(3) Engage the overhead console wire harness connector onto the mount on the compass mini-trip computer module housing by aligning the channels on the connector with the tab on the mount and pushing the connector firmly toward the right side of the overhead console housing.

(4) Install and tighten the four screws that secure the compass mini-trip computer module to the overhead console housing. Tighten the screws to 2.2 N·m (20 in. lbs.).

(5) Install the overhead console onto the headliner. Refer to **Overhead Console** in the Removal and Installation section of this group for the procedures.

(6) Reconnect the battery negative cable.

NOTE: If a new compass mini-trip computer has been installed, the compass will have to be calibrated and the variance set. Refer to **Compass Variation Adjustment and Compass Calibration** in the Service Procedures section of this group for the procedures.

OVERHEAD CONSOLE READING AND COURTESY LAMP HOUSING

REMOVAL

(1) Disconnect and isolate the battery negative cable.

(2) Remove the compass mini-trip computer module from the overhead console housing. Refer to **Compass Mini-Trip Computer** in the Removal and Installation section of this group for the procedures.

REMOVAL AND INSTALLATION (Continued)

(3) Remove the two screws that secure the reading and courtesy lamp housing to the overhead console housing (Fig. 8).

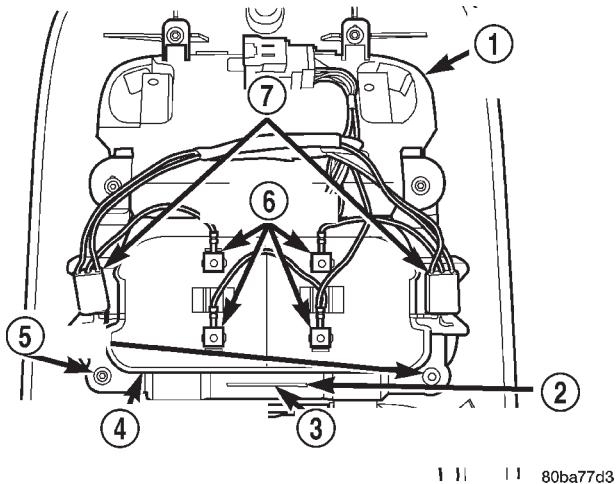

Fig. 8 Overhead Console Reading and Courtesy Lamp Housing Remove/Install

- 1 - COMPASS MINI-TRIP COMPUTER
- 2 - SLOT
- 3 - SUNGLASSES STORAGE BIN DAMPER SPRING
- 4 - OVERHEAD CONSOLE READING AND COURTESY LAMP HOUSING
- 5 - SCREWS (2)
- 6 - BULB HOLDERS
- 7 - SWITCHES

(4) Pull the reading and courtesy lamp housing away from the overhead console housing far enough to turn it over for access to the lamp bulbs.

(5) Remove both reading and courtesy lamp bulbs from their bulb holders by pulling them straight out from the holders.

(6) Remove both switches from their mounting slots by sliding them towards their respective outboard ends of the reading and courtesy lamp housing.

(7) Remove the four bulb holders from their mounting holes in the reading and courtesy lamp housing by depressing the latch on each side of each holder and pushing the bulb side of the holder out through the wire side of the mounting hole.

(8) Remove the reading and courtesy lamp housing from the overhead console housing.

INSTALLATION

(1) Install each of the four bulb holders into their mounting holes in the reading and courtesy lamp housing by inserting the bulb side of the holder into the wire side of the mounting hole and pushing it through the mounting hole until both latches are engaged with the lamp housing.

(2) Install both switches into their mounting slots by sliding them inboard from their respective ends of

the reading and courtesy lamp housing until they snap into place.

(3) Install both reading and courtesy lamp bulbs into their bulb holders by pushing them straight into the holders.

(4) Position the reading and courtesy lamp housing onto the overhead console housing. Be certain that the sunglasses storage bin damper spring is engaged in the slot on the rear flange of the reading and courtesy lamp housing.

(5) Install and tighten the two screws that secure the reading and courtesy lamp housing to the overhead console housing. Tighten the screws to 2.2 N-m (20 in. lbs.).

(6) Install the compass mini-trip computer module into the overhead console housing. Refer to **Compass Mini-Trip Computer** in the Removal and Installation section of this group for the procedures.

(7) Reconnect the battery negative cable.

SUNGLASSES STORAGE BIN

REMOVAL

(1) Disconnect and isolate the battery negative cable.

(2) Remove the reading and courtesy lamp housing from the overhead console. Refer to **Overhead Console Reading and Courtesy Lamp Housing** in the Removal and Installation section of this group for the procedures.

(3) Unlatch and remove the sunglasses storage bin from the overhead console housing.

INSTALLATION

(1) Position the sunglasses storage bin into the overhead console housing.

(2) Engage the latch of the sunglasses storage bin with the latch striker on the rear of the storage bin opening in the overhead console housing.

(3) Be certain that the sunglasses storage bin pivot shaft is located in the two pivot receptacles just behind the reading and courtesy lamp lenses in the overhead console housing.

(4) Be certain that the sunglasses storage bin damper spring is installed on the pivot shaft with the two end tabs of the spring engaged with the flats on the rear of the shaft, and the center tab engaged over the front of the shaft.

(5) Install the reading and courtesy lamp housing onto the overhead console. Refer to **Overhead Console Reading and Courtesy Lamp Housing** in the Removal and Installation section of this group for the procedures.

(6) Reconnect the battery negative cable.

REMOVAL AND INSTALLATION (Continued)

GARAGE DOOR OPENER STORAGE BIN DOOR

REMOVAL

- (1) Disconnect and isolate the battery negative cable.
- (2) Remove the overhead console from the headliner. Refer to **Overhead Console** in the Removal and Installation section of this group for the procedures.
- (3) Remove the two screws that secure the garage door opener storage bin door pivot and bumper block to the overhead console housing (Fig. 9).

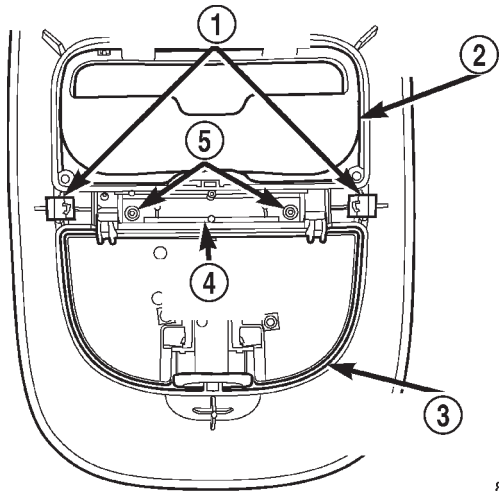

80ba77d4

Fig. 9 Garage Door Opener Storage Bin Door Remove/Install

- 1 - SPRING CLIPS
- 2 - SUNGLASSES STORAGE BIN
- 3 - GARAGE DOOR OPENER STORAGE BIN DOOR
- 4 - PIVOT AND BUMPER BLOCK
- 5 - SCREW (2)

- (4) Remove the garage door opener storage bin door pivot and bumper block from the overhead console housing.
- (5) Unlatch and remove the garage door opener storage bin door from the overhead console housing.

INSTALLATION

- (1) Position the garage door opener storage bin door into the overhead console housing.
- (2) Engage the latch of the garage door opener storage bin door with the latch striker on the rear of the storage bin opening in the overhead console housing.
- (3) Be certain that both garage door opener storage bin door pivot pins are located in the two pivot receptacles in the overhead console housing just behind the sunglasses storage bin.

- (4) Position the garage door opener storage bin door pivot and bumper block onto the overhead console housing.
- (5) Install and tighten the two screws that secure the garage door opener storage bin door pivot and bumper block to the overhead console housing. Tighten the screws to 2.2 N-m (20 in. lbs.).
- (6) Install the overhead console onto the headliner. Refer to **Overhead Console** in the Removal and Installation section of this group for the procedures.
- (7) Reconnect the battery negative cable.

AMBIENT TEMPERATURE SENSOR

REMOVAL

- (1) Disconnect and isolate the battery negative cable.
- (2) Locate the ambient temperature sensor, on the right side of the radiator yoke behind the grille (Fig. 10).

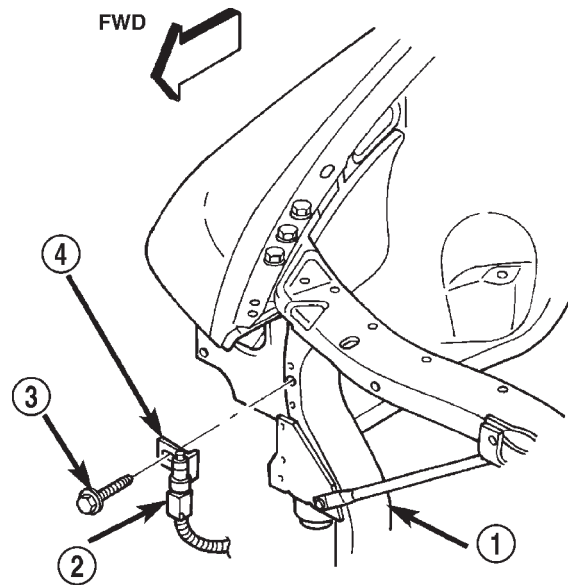

80a98360

Fig. 10 Ambient Temperature Sensor Remove/Install

- 1 - YOKE
- 2 - CONNECTOR
- 3 - SCREW
- 4 - SENSOR

- (3) Disconnect the wire harness connector from the ambient temperature sensor connector receptacle.
- (4) Remove the one screw that secures the ambient temperature sensor bracket to the radiator yoke.
- (5) Remove the ambient temperature sensor from the radiator yoke.

REMOVAL AND INSTALLATION (Continued)

INSTALLATION

- (1) Position the ambient temperature sensor onto the radiator yoke.
- (2) Install and tighten the one screw that secures the ambient temperature sensor bracket to the radiator yoke. Tighten the screw to 5.6 N·m (50 in. lbs.).
- (3) Reconnect the wire harness connector to the ambient temperature sensor connector receptacle.
- (4) Reconnect the battery negative cable.

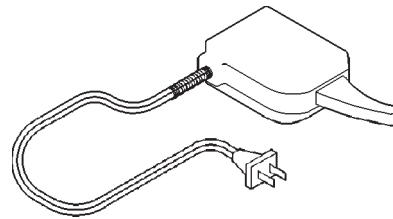
SPECIAL TOOLS**OVERHEAD CONSOLE SYSTEMS**

Degaussing Tool 6029